



034

SPECIFICATIONS

SPECIFICATION

of work to be done and materials to be used in carrying out the works shown on the accompanying drawings

Nichols Shed

(project name)

Sh 12 Waimamaku

(project address)

Nichols

(owners name)

FAR NORTH DISTRICT COUNCIL
Approved Document

Job Number: 201692

Date: 14/12/15

1012 TABLE OF CONTENTS

1012	TABLE OF CONTENTS.....	2
1220	GENERAL REQUIREMENTS.....	3
1233	DOCUMENTS REFERENCED.....	7
2200	GROUNDWORKS AND PREPARATION.....	9
3110	CONCRETE WORK.....	11
3800	TIMBER FRAMING.....	14
4161T	THERMAKRAFT UNDERLAYS, FOILS & DPC.....	16
4241S	STEEL & TUBE PROFILED METAL WALL CLADDING.....	21
4311S	STEEL & TUBE PROFILED METAL ROOFING.....	26
4520	ALUMINIUM WINDOWS AND DOORS.....	31
7410	RAINWATER SPOUTING SYSTEM.....	33

1220 GENERAL REQUIREMENTS

1. GENERAL

1.1 THE WORKS

The works are as described in this specification and shown on the drawings.

1.2 PERSONNEL

Owner: The person defined as "owner" in the New Zealand Building Code.

Contractor: The person contracted by the owner to carry out the contract.

1.3 THE SITE

The site of the works, the site address and the legal description are listed under the sections 1210 PROJECT. Confine access and work to the area of site indicated on the drawings.

1.4 SPECIFICATION SECTIONS

Sections are for reference and convenience only and do not constitute individual trade sections or work elements. Read all sections together and read this section with all other sections.

1.5 INTERPRETATIONS

Required: Required by the documents, or by a statutory authority.

Proprietary: Identifiable by naming the manufacturer, supplier, installer, trade name, brand name, catalogue or reference number.

Approval: Approval in writing.

Direction: Direction in writing.

Notified: Notified in writing.

1.6 ABBREVIATIONS

The following abbreviations are commonly used throughout the specification:

AS	Australian Standard
AS/NZS	Joint Australian/New Zealand Standard
BCA	Building Consent Authority
BRANZ	Building Research Association of New Zealand
LBP	Licensed Building Practitioner
NZBC	New Zealand Building Code
NZS	New Zealand Standard
NZS/AS	Joint New Zealand/Australian Standard
NUO	Network Utility Operator
OSH	Occupational Safety and Health
RBW	Restricted Building Work
TA	Territorial Authority

1.7 INCONSISTENCIES

If there are any inconsistencies, errors or omissions in or between documents, the contractor must seek direction in resolving it. Figured dimensions take precedence over scaled dimensions; drawings to a larger scale take precedence over drawings to a smaller scale and drawings take precedence over specification.

1.8 SUBSTITUTIONS

A substitution may be proposed where specified products are not available, or if substitute products are brought to the attention of and are considered by the owner as equivalent or superior to those specified. Except where a specified product is not available, the owner is not bound to accept any substitutions.

Notify proposed substitution of specified products. Include sufficient information to allow the owner to confirm that the substitution is equivalent or superior to that specified.

Advise the owner whether an amendment will or may be required to the Building Consent and the expected costs of such amendment.

- 1.9 **THE WORDS "PROVIDE" OR "FIX"**
The words "provide" (or "supply") or "fix" if used separately mean "provide and fix" unless explicitly stated otherwise.
- 1.10 **MANUFACTURERS AND SUPPLIERS**
Manufacturers and suppliers requirements, instructions, specifications or details are those issued by them for their particular material, product or component and are the latest edition.
- 1.11 **REFERENCED DOCUMENTS**
Reference is made to various New Zealand Building Code (NZBC) acceptable solutions (AS) and verification methods (VM) for criteria and/or methods used to establish compliance with the Building Act 2004. Reference is also made to various Standards produced by Standards New Zealand (NZS, AS/NZS) and to listed Acts, Regulations and various industry codes of practice and practice guides. The latest edition (including amendments and provisional editions) at the date of this specification applies unless stated otherwise. Documents cited both directly and within other cited publications are part of this specification.
- 1.12 **PRECEDENCE OF REFERENCED DOCUMENTS**
This specification takes precedence in the event of it being at variance with and requiring a higher standard than, the cited documents. Resolution of any variance must be confirmed in writing and where Building Consent is affected, the change notified to the BCA for advice as to whether an amendment is required to the Building Consent Authority.
- 1.13 **BUILDING CONSENT COMPLIANCE**
It is an offence under the Building Act 2004 to carry out any work not in accordance with the Building Consent. Refer the resolution of matters concerning compliance to the owner for a direction. Where Building Consent is affected refer any change to the BCA for advice as to whether an amendment is required to the Building Consent.
- 1.14 **STATUTORY OBLIGATIONS**
Comply with all statutory obligations and regulations of regulatory bodies controlling execution of the works.
- 1.15 **BUILDING CONSENT**
Obtain the original or copies of the Building Consent form and documents from the owner and keep on site. Liaise with the BCA and/or the building certifier for all required notices and all inspections required during construction to ensure compliance. Return the consent form and documents to the owner on completion.
- 1.16 **INSPECTIONS**
Do not proceed with work noted on the Building Consent for inspection until it has been inspected and passed by the BCA inspector.
- 1.17 **KEY PERSONNEL**
Provide names and contact detail of LBP's/ key personnel. Prior to Restricted Building Work being carried out, provide names, registrations numbers (where appropriate) and contact detail of LBP's that are required for RBW by the Building Consent Authority as part of the Building Consent.
- Include the following as applicable:
- Person with the appropriate site license
 - Carpenter
 - Registered drainlayer
 - Registered plumber
 - Registered gasfitter
 - Registered electrician
 - Roofer
 - Block layer
 - Bricklayer
 - External plasterer

- External window manufacturer
 - Waterproof membrane applicator
- 1.18 **PRODUCER STATEMENTS AND LBP DOCUMENTATION**
When Records of Work or producer statements verifying construction are required, for the application for the Code Compliance Certificate, provide copies to both the BCA and the owner. Provide LBP documents and producer statements in the form required by the BCA.
- 1.19 **CODE COMPLIANCE CERTIFICATE**
Provide documentation that the Owner requires in order to obtain a Code Compliance Certificate for the consented work.
- 1.20 **TRADE GUARANTEES AND WARRANTIES**
Where specific trade guarantees/warranties are offered covering materials and/or execution of proprietary products or complete installations, or are required as a condition of Building Consent, provide guarantees/warranties to the owner.
- 1.21 **SITE ACCOMMODATION**
Provide, erect and maintain scaffolding, sheds, toilets, water, power and hoardings. Allow for cartage, craneage, plant hire and storage. Arrange for temporary works and services necessary for the completion of the works.
- 1.22 **HEALTH AND SAFETY**
Make the works safe and provide and maintain a safe working environment. Ensure that all those working on or visiting the site are aware of the rules governing site safety, are properly supervised and are not unnecessarily exposed to hazards.
- 1.23 **PROTECT THE WORKS**
Protect parts of the work liable to damage until completion of the works. Take all precautions necessary to protect the works from damage by unauthorised entry or inclement weather. Brace and support all parts of the works against damage during construction.
- 1.24 **STORAGE AND PROTECTION**
Provide temporary storage areas and protective covers and screens. Fillet stack and protect all framing and structural members from moisture and contamination. Completely protect finishing materials from the weather and damage and store in accordance with the manufacturer's requirements. Protect fabricated elements from the weather and damage, and store in accordance with suppliers requirements.
- 1.25 **ANTIQUITIES AND ITEMS OF VALUE AND INTEREST**
Report immediately the finding of any fossils, antiquities, pre-1900 items, or objects of value. Ensure they remain undisturbed until approval is given for their removal.
- 1.26 **MEANS OF COMMUNICATION**
All directions and approvals in writing.
- 1.27 **WORKING HOURS**
Work on site is restricted to between 0800 to 1800, Monday to Friday, excluding statutory holidays. Work outside these hours may be permitted, with prior approval in writing by the owner.
- 1.28 **RESTRICTIONS**
Do not:
 - smoke on site
 - light rubbish fires on the site
 - bring dogs on to or near the site
 - bring radios/audio players on to the site.

- 1.29 **QUALITY ASSURANCE**
Carry out and record regular checks of material quality and accuracy. Provide all necessary materials, equipment, plant, attendances, supervision, inspections and programming to ensure required standards are met.
- 1.30 **DAMAGE AND NUISANCE**
Prevent damage and nuisance from water, fire, smoke, vehicles, dust, rubbish, noise and other causes resulting from the contract works. Comply with the requirements of the TA and relevant Acts and Standards.
- 1.31 **SET-OUT AND DATUM**
Set out the works to conform with the drawings. Establish a permanent site datum to confirm the existing ground floor level and its relationship to other existing and new building levels.
- 1.32 **EXECUTION OF THE WORK**
Conform to the requirements of this specification. Ensure work is level, plumb, and true to line and face. Employ only experienced workers familiar with the materials and techniques specified.
- 1.33 **MATERIALS AND PRODUCTS**
Use only new materials and products, unless stated otherwise, of the specified quality and complying with cited documents.
- 1.34 **COMPATIBILITY**
Ensure all parts of a construction or finish are compatible and their individual use approved by the manufacturers and suppliers of other parts of the system. Source all parts of a system from a single manufacturer or supplier.
- 1.35 **CLEAR AWAY**
Regularly clear away trade debris, unused materials and elements from the site. On completion of the work leave the building clean and ready for occupancy, with all services operating and mechanical parts in good working order. Remove temporary markings, coverings and protective wrappings.
- 1.36 **CLEAN**
Clean and wash down external surfaces to remove dirt, debris and marking. Clean interior surfaces including floors, glass, cabinetwork, joinery, sanitary and hardware items.

1233 DOCUMENTS REFERENCED

1. GENERAL

Documents listed below are, when referred to in the text, part of this specification. However, this specification takes precedence in the event of it being at variance with and requiring a higher standard than any cited document.

1.1 ACTS AND REGULATIONS

Building Act 2004

Gas (Safety and Measurement) Regulations 2010

Health and Safety in Employment Act 1992

Electricity (Safety) Regulations 2010

Plumbers, Gasfitters and Drainlayers Act 2006

1.2 NEW ZEALAND BUILDING CODE VERIFICATION METHODS

NZBC E2/VM1 External moisture

NZBC G12/VM1 Water supplies

1.3 NEW ZEALAND BUILDING CODE ACCEPTABLE SOLUTIONS

NZBC B1/AS1 Structure - general

NZBC B2/AS1 Durability

NZBC C/AS1-AS7 Protection from fire

NZBC D1/AS1 Access routes

NZBC E1/AS1 Surface water

NZBC E2/AS1 External moisture

NZBC E2/AS3 External moisture

NZBC F2/AS1 Hazardous building materials

NZBC F7/AS1 Domestic smoke alarms

NZBC G1/AS1 Personal hygiene

NZBC G10/AS1 Piped services - Gas

NZBC G11/AS1 Gas as an energy source

NZBC G12/AS1 Water supplies

NZBC G13/AS2 Foul water - Drainage

1.4 NEW ZEALAND STANDARDS

AS/NZS 1604.3 Specification for preservative treatment - Plywood

NZS/AS 1884 Floor coverings - Resilient sheet and tiles - Installation practices

AS/NZS 2269.0 Plywood - Structural - Specifications

AS/NZS 2455.1 Textile floor coverings - Installation practice - General

AS/NZS 2455.2 Textile floor coverings - installation practice - Carpet tiles

AS/NZS 2589 Gypsum linings - Application and finishing

AS/NZS 2642.2 Polybutylene pipe systems - Polybutylene pipe for hot and cold water applications

AS/NZS 2699.1 Built-in components for masonry construction Wall ties

AS/NZS 3000 Electrical installations (known as the Australian/NZ Wiring Rules)

NZS 3101.1 Concrete structures standard

NZS 3103 Sands for mortars and plasters

NZS 3104 Specification for concrete production

NZS 3109 Concrete construction

NZS 3114 Concrete surface finishes

AS/NZS 3500.2:2003 Plumbing and drainage - Sanitary plumbing and drainage

NZS 3501 Specification for copper tubes for water, gas and sanitation

NZS 3602 Timber and wood-based products for use in building

NZS 3603 Timber structures standard

NZS 3604 Timber-framed buildings

NZS 3622 Verification of timber properties

NZS 3631 New Zealand national timber grading rules

AS/NZS 4130 Polyethylene (PE) pipes for pressure applications

NZS 4210 Masonry construction materials and workmanship

NZS 4211 Specification for the performance of windows

NZS 4218 2004 Energy efficiency - Housing and small building envelope

NZS 4223.1 Glazing in buildings - Glass selection and glazing

NZS 4223.3	Glazing in buildings - Human impact safety requirements
NZS 4223.4	Glazing in buildings - Wind, dead, snow and live actions
NZS 4229	Concrete masonry buildings not requiring specific engineering design
NZS 4251.1	Solid plastering - Cement plasters for walls, ceilings and soffits
AS/NZS 4666	Insulating glass units
AS/NZS 4671	Steel reinforcing materials
AS/NZS 4858	Wet area membranes
AS/NZS 5601.1: 2010	Gas installations - general installations
NZS 6803	Acoustics - Construction noise

- 1.5 BUILDING RESEARCH ASSOCIATION OF NEW ZEALAND (BRANZ)
 Weathertight Solutions Vol. 2: Stucco
 Good practice guide: Tiling
 Good practice guide: Membrane roofing
 Bulletin 441 - Sealed joints in external claddings - 2. Sealants
 Bulletin 519 - Fasteners selection

1.6 OTHER DOCUMENTS

Cement & Concrete Association of New Zealand

- [CCANZ CP 01](#): Code of practice for weathertight concrete and concrete masonry construction

WorkSafe New Zealand (OSH)

- [Approved code of practice for safety in excavation and shafts for foundations](#)
- [Repainting lead based paints](#)

Waterproofing Membrane Association Inc.

- [WMAI CoPTM](#): Code of practice for torch-on membrane systems for roofs and decks

New Zealand Demolition and Asbestos Association (NZDAA)

- [Best Practice Guideline for Demolition in New Zealand](#).
- [New Zealand Guidelines for the Management and Removal of Asbestos](#)

New Zealand Metal Roofing Manufacturers Inc

- [NZMRM COP](#): NZ Metal roof and wall cladding: Code of practice

Window Association of New Zealand Incorporated (WANZ)

- [WANZ PQAS](#): Powder Coating Quality Assurance System
- [WANZ Installation Guide](#): The WANZ Guide to Window Installation as described in E2/AS1 Amendment 5.

2200 GROUNDWORKS AND PREPARATION

1. GENERAL

Refer to 1213 SELECTIONS/drawings for specific product, material, accessories and finish selections.

1.1 QUALIFICATIONS

Carry out work using persons competent and experienced in the trade.

1.2 SITE SAFETY

Provide proper support for excavations. Cover holes and fence off open trenches and banks.

2. PRODUCTS

2.1 FILLING MATERIALS

Volcanic tuff:	Scoriaceous tuff of variable grading excluding silt or clay material, capable of being placed and compacted as specified.
Rock fill:	Hard material comprising rock, broken stone, hard brick, concrete, run of pit scoria, or other comparable inert material capable of being placed and compacted as specified.
Sand fill:	Clean sand of such grading in particle size as to allow for mechanical compaction to 90% maximum density.
Hardcore:	Scoria or crushed rock to GAP (General All Passing) 40 grading.
Granular base:	Screened crushed gravel or scoria graded in size from 20mm to 7mm, clean. When tested with a standard sieve of 4.75 opening no material is to pass.
Dressing course:	Scoria to GAP 20 grading, or "dirty footpath scoria", or equivalent "all in" graded crushed metal aggregate.
Free-draining aggregate:	Scoria or crushed gravel graded 50 to 14 clean.

3. EXECUTION

3.1 EXCAVATION GUIDELINES

Carry out excavation to the guidelines set in WorkSafe NZ [Approved Code of Practice for Safety in Excavation and Shafts for Foundations](#).

3.2 PROTECT EXISTING

Protect from damage existing buildings, structures, roads, paving and services nominated on the drawings as being retained, throughout the course of the work.

3.3 SURFACE PREPARATION

To [NZS 3604](#), 3.5 **Site preparation**, remove all turf, vegetation, trees, topsoil, stumps and rubbish from the area being built on.

3.4 UNDERGROUND ELEMENTS AND SERVICES

Break out and remove underground elements and redundant services. Report for instructions when unexpected voids, made-up ground or services are encountered. Seal off the ends of drains or remove to NUO approval.

3.5 STOCKPILE TOPSOIL

Stockpile excavated topsoil on site where directed. Keep separate from other excavated materials. Spread and level where directed before completion of the works.

3.6 GENERAL EXCAVATION

Trim ground to required profiles, batters, falls and levels. Remove loose material. Protect cut faces from collapse. Keep excavations free from water.

3.7 EXCAVATION FOR FOUNDATIONS

Take foundation excavations to depths shown. Keep trenches plumb and straight, bottoms level and solid, stepped as detailed and clean and free of water.

3.8

INADEQUATE BEARING

If bearing is inadequate then excavate further and backfill with material as follows:

Slabs on grade:	Hardfill
Footings:	10 MPa concrete
Service trenches:	Hardfill

If excavation exceeds the required depths, backfill and compact to the correct level with listed material.

3.9

GRANULAR BASE FOR SLABS

To [NZS 3604](#), 7.5.3 **Granular base**. Consolidate with a vibrating roller. Blind the surface with coarse sand or sand/cement and roll ready to receive a damp-proof membrane.

3.10

GENERAL BACKFILLING

Compact backfilling in 150mm layers, with the last 200mm in clean topsoil, lightly compacted and neatly finished off.

3110 CONCRETE WORK

1. GENERAL

Refer to 1213 SELECTIONS/drawings for specific product, material, accessories and finish selections.

1.1 QUALIFICATIONS

Carry out work using persons competent and experienced in the trade. Structural and foundation work to be carried out by or supervised by the appropriate LBP.

2. PRODUCTS

2.1 REINFORCEMENT

Bars to [AS/NZS 4671](#), grade 300E deformed, other than for ties, stirrups and spirals, unless shown otherwise on the drawings. Welded reinforcing mesh to [AS/NZS 4671](#) Class E. Mild drawn steel tying wire not less than 1.2mm diameter.

2.2 MESH FOR SLABS TO NZS 3604 OR NZS 4229

For slabs on ground, welded reinforcing mesh to [AS/NZS 4671](#), minimum to [NZBC B1/AS1](#) - Grade 500E, 2.27kg/m² (1.14kg/m² in each direction).

2.3 SPACERS AND CHAIRS

Precast concrete or purpose made moulded PVC. Use concrete spacer blocks only where the concrete surface is not exposed in the finished work.

2.4 CONCRETE

Strength as selected. Ready-mix normal grade, maximum aggregate size 19mm to [NZS 3104](#). Site mixed prescribed grade, using either separate batching of sand and coarse aggregate, or builder's mix, to [NZS 3104](#).

3. EXECUTION

3.1 HANDLE AND STORE REINFORCING

Handle and store reinforcing steel and accessories without damage or contamination. Ensure reinforcement is clean and remains clean and free of contamination that may reduce bonding capacity.

3.2 FALSEWORK AND FORMWORK

Use falsework and formwork of sufficient strength to retain and support the wet concrete to the required profiles and tolerances. Select formwork finish to produce the specified finished quality.

3.3 CUT AND BEND

Cut and bend bars using proper bending tools to avoid notching and to the requirements of [NZS 3109](#). Do not rebend bars without written approval. Bend main reinforcing bars, stirrups and ties to the former pin diameters as given in [NZS 3109](#), figure 3.1, **Standard bend, hook and stirrup**.

3.4 SECURE REINFORCEMENT

Secure reinforcement adequately with tying wire and place, support and secure against displacement when concreting. Bend tying wire back well clear of the formwork. Spacing as dimensioned, or if not shown, to the clear distance minimums laid down in [NZS 3109](#), 3.3. **Hooks and bends**.

3.5 LAPPED SPLICES

Set length of laps, where not dimensioned on the drawings, in accordance with [NZS 3109](#): 3.7, **Splices in reinforcement**. Increase laps of plain round steel by 100%.

3.6 MESH LAPS FOR SLABS TO NZS 3604 OR NZS 4229

For slabs on ground, mesh to be lapped and tied, so the outermost wires overlap by the greater of:- the spacing of the cross wires plus 50mm or, 150mm or, manufacturer's requirements. Do not count bar extensions beyond the outermost cross wire.

- 3.7 **REINFORCEMENT COVER TO NZS 3604**
Minimum cover to all reinforcing bars, stirrups, ties and spirals, as shown on drawings. Where cover is not shown on drawings provide minimum cover to [NZS 3604](#) requirements.
- 3.8 **REINFORCEMENT COVER TO NZS 4229**
Minimum cover to all reinforcing bars, stirrups, ties and spirals, as shown on drawings. Where cover is not shown on drawings provide minimum cover to [NZS 4229](#) requirements.
- 3.9 **REINFORCEMENT COVER TO NZS 3101.1**
Minimum cover to all reinforcing bars, stirrups, ties and spirals, as shown on drawings. Where cover is not shown on drawings provide minimum cover to [NZS 3101.1](#), table 3.6, **Minimum required cover for a specified intended life of 50 years**. Sub-soil cover to [NZS 3101.1](#), to suit soil and groundwater conditions. Fix chairs for top reinforcement in slabs at 1.0 metre centres or to ensure adequate support. Cover tolerances to [NZS 3109](#), 3.9, Tolerances for reinforcement.
- 3.10 **CONCRETE PLACEMENT**
To comply with [NZS 3109](#).
- 3.11 **SURFACE FINISHES**
To comply with [NZS 3114](#), section 105 **Specification of finishes**, or as denoted on the drawings. Formwork linings and surface finishes as nominated for both fair face and concealed or exposed surfaces. Surface tolerances to comply with [NZS 3114](#), section 104 **Surface tolerances** and 105.3.2.
- 3.12 **DAMP-PROOF MEMBRANE**
Apply membrane to prepared basecourse with 150mm laps between sheets. Tape seal laps and penetrations with 50mm wide pressure sensitive plastic tape. Refer to drawings for perimeter details.
- 3.13 **CASTING IN**
Build in grounds, bolts and fixings for wall plates and bracing elements, holding down bolts, pipes, sleeves and fixings as required. Form pockets, chases and flashing grooves as required. No grounds exceeding 100mm in length. Minimum cover on conduits 40mm. Do not encase aluminium items in concrete. Do not paint steel embedded items more than 25mm into the concrete encasement. Cut back form ties to specified cover and fill the cavities with mortar. Wrap all pipes embedded in concrete with tape to break the bond and to allow for expansion.
- 3.14 **FLOOR SLABS TO NZS 3604**
Slabs on ground to [NZS 3604](#) as modified by [NZBC B1/AS1](#) and [NZBC E2/AS3](#). Construct to [NZS 3604](#), 4.5 **Concrete and concrete masonry** and [NZS 3604](#), 7.5, **Concrete slab-on-ground floors in timber buildings** as modified by [NZBC B1/AS1](#), 3.0 **Timber**. Lay to true and straight surfaces, screeded, floated and steel (manual or power) trowelled finish. Tolerance on flatness: maximum 3mm gradual deviation over a 3 metre straight-edge, to [NZS 3114](#), 304, **Surface tolerances**. Allow for free joints maximum 24m centres to [NZBC B1/AS1](#), 3.1.13 **NZS 3604 New clause**.
In the Canterbury Earthquake Region comply with the changes to [NZS 3604](#) in [NZBC B1/AS1](#).
- 3.15 **FLOOR SLABS TO NZS 4229**
Slabs on ground to [NZS 4229](#) as modified by [NZBC B1/AS1](#) and [NZBC E2/AS3](#). Construct to [NZS 4229](#), 6, **Footings** and [NZS 4229](#), 7, **Foundation walls and concrete slab-on-ground** as modified by [NZBC B1/AS1](#), 2.0 **Masonry**. Lay to true and straight surfaces, screeded, floated and steel (manual or power) trowelled finish. Tolerance on flatness: maximum 3mm gradual deviation over a 3 metre straight-edge, to [NZS 3114](#), 304, **Surface tolerances**. Allow for free joints maximum 18m centres to [NZS 4229](#), 7.8.5.3 **Free joints**.
In the Canterbury Earthquake Region comply with the changes to [NZS 4229](#) in [NZBC B1/AS1](#).

- 3.16 **SAW CUTS TO NZS 3604**
Cut slabs where indicated on the drawings as required to control shrinkage cracking. Form by saw cutting the slab (blade width approximately 5 mm) to a quarter of the depth of the slab after it has hardened (saw cutting shall take place no later than 24 hours after initial set for average ambient temperatures above 20 °C, and 48 hours for average ambient temperatures below 20 °C). If saw cuts are not indicated on the drawings, than provide saw cuts as per the requirements for shrinkage control joints in [NZS 3604](#).
- 3.17 **SAW CUTS TO NZS 4229**
Cut slabs where indicated on the drawings as required to control shrinkage cracking. Form by saw cutting the slab (blade width approximately 5 mm) to a quarter of the depth of the slab after it has hardened (saw cutting shall take place no later than 24 hours after initial set for average ambient temperatures above 20 °C, and 48 hours for average ambient temperatures below 20 °C). If saw cuts are not indicated on the drawings, than provide saw cuts as per the requirements for shrinkage control joints in [NZS 4229](#).
- 3.18 **SAW CUTS**
Cut slabs where indicated on the drawings and as required to control shrinkage cracking. Carry out cutting as soon as possible, without causing tear-out of aggregate and before shrinkage cracking has occurred, generally within 24 hours of pouring. Where saw cuts are made, cut out 100mm of every second wire of the mesh for a length of 50mm each side of the saw cut position. Saw cuts: 1/3rd slab depth, or 30mm minimum.
- 3.19 **SURFACE REPAIRS**
Make good surface defects as soon as forms are stripped. Make good hollows or bony areas with 1:2 mortar, finished to the same tolerances as the parent concrete. Fill tie rod holes with 1:2 mortar.
- 3.20 **CURING OF CONCRETE**
Keep damp for not less than seven days. Ensure curing of slabs commences as soon as possible after final finishing, by the use of continuous water sprays, or ponding. Alternately, apply a curing membrane. Ensure any membrane used will not affect subsequent applied finishes.
- 3.21 **STRIKE FORMWORK**
Strike formwork without damaging or overloading structure.

3800 TIMBER FRAMING

1. GENERAL

Refer to 1213 SELECTIONS/drawings for specific product, material, accessories and finish selections.

Use experienced competent carpenter familiar with the materials and techniques specified. Work to be carried out by or supervised by the appropriate LBP.

2. PRODUCTS

2.1 TIMBER FRAMING GENERALLY

Species, grade and level of treatment to [NZBC B2/AS1](#), [NZS 3602](#), tables 1 to 3 **Requirements for wood-based building components...**, and moisture content to [NZS 3602](#), table 4 **Allowable moisture content.....** Structural Grade (SG) to [NZS 3604](#), [NZS 3622](#) with properties to [NZS 3603](#).

2.2 ACCESSORIES

Damp-proof course:	High impact embossed polyethylene
Stud straps	Polypropylene tape run horizontal at 300mm centres over flexible wall underlay, for drained cavities with stud spacings greater than 450mm.
Nails, bolts and screws:	Steel, stainless steel, galvanized steel of pattern to suit the location and to BRANZ BU 519: Fasteners selection. To NZS 3604 , 4 Durability and NZBC E2/AS1 .
Nail plates connectors:	Stainless steel and/or galvanized steel toothed or nailed plates to the plate manufacturer's design for the particular locations as shown on the drawings and to NZS 3604 , 4 Durability . Galvanized steel and stainless steel connectors and brackets to the connector manufacturer's design for locations shown on drawings and to NZS 3604 , 4 Durability and NZBC E2/AS1
Corrosion risk	For exterior timber, timber in damp areas and timber subject to occasional wetting, use only stainless steel (or equivalent) fixings and connectors, when the timber is treated with; Copper Azole (CuAz, Preservative code 58), Alkaline Copper Quaternary (ACQ, Preservative code 90), Micronise Copper Azole (code 88) or Micronised Copper Quaternary (code 89). For interior timber, treated with copper-based timber preservatives (H3.2 or higher), use a minimum of hot-dipped galvanized steel fixings and fasteners.

3. EXECUTION

3.1 ATTENDANCE

Provide and fix blocks, noggs, openings and other items as required by others.

3.2 MOISTURE CONTENT

Maximum allowable moisture content to [NZS 3602](#), table 4 **Allowable moisture content...**, for framing supporting interior linings:

Framing at erection	24%
Framing at enclosure	20%
Framing at lining	16%

3.3 EXECUTION GENERALLY

To [NZS 3604](#) except as varied in this specification. To include those methods, practices and processes contained in the unit standards for the National Certificate in Carpentry and the National Certificate in Joinery (cabinetry, exterior joinery, stairs). Set out framing in accordance with the requirements of [NZS 3604](#) and as required to support sheet linings and claddings.

3.4 INSTALL FLOOR, WALL AND ROOF FRAMING

Floors and bottom plates framed and fastened to NZS 3604, 7 **Floors**. Frame walls to required loading and bracing complete with lintels, sills and nogs, all fabricated and fastened to NZS 3604, 8 **Walls**. Frame roof to required loading and bracing complete with valley boards, ridge boards and purlins to NZS 3604, 10 **Roof framing**. Design and fit roof trusses complete with anchorage. All fabricated and fastened to NZS 3604, 9 **Posts**, and NZS 3604, 10 **Roof framing**.

4161T THERMAKRAFT UNDERLAYS, FOILS & DPC

1. GENERAL

This section relates to the application of **Thermakraft Industries (NZ) Ltd**, DPC, DPM, underfloor foil insulation, wall underlays and roofing underlays.

1.1 RELATED WORK

Refer to ~ for ~

1.2 ABBREVIATIONS AND DEFINITIONS

Refer to the general section 1232 INTERPRETATION & DEFINITIONS for abbreviations and definitions used throughout the specification.

The following abbreviations apply specifically to this section:

NZMRM New Zealand Metal Roofing Manufacturers Inc.

The following definitions apply specifically to this section:

Wall underlay the same meaning as defined in [NZBC E2/AS1](#), covering kraft based and synthetic wall underlays, sometimes called, wall wraps, building wraps or building papers.

Documents

1.3 DOCUMENTS

Refer to the general section 1233 REFERENCED DOCUMENTS. The following documents are specifically referred to in this section:

NZBC C/AS1-AS7	Protection from fire
NZBC E2/AS1	External moisture
AS 1530.2	Methods for fire tests on building materials, components and structures - Test for flammability of materials
NZS 2295	Pliable, permeable building underlays
AS/NZS 2904	Damp-proof courses and flashings
NZS 3604	Timber-framed buildings
AS/NZS 4200.1	Pliable building membranes and underlays - Materials
NZS 4214	Methods of determining the total thermal resistance of parts of buildings
AS/NZS 4389	Roof safety mesh
AS/NZS 4534	Zinc and zinc/aluminium-alloy coatings on steel wire
NZMRM CoP	NZ metal roof and wall cladding Code of Practice

1.4 MANUFACTURER/SUPPLIER DOCUMENTS

Thermakraft documents relating to work in this section are:
Thermakraft product manual and technical data sheets.

[BRANZ Appraisal 329](#) - Supercourse 500 Damp-Proof Course and Concealed Flashing
[BRANZ Appraisal 651](#) - Thermakraft Covertex™ 407 Fire Retardant Self Supporting Synthetic Roofing Underlay
[BRANZ Appraisal 695](#) - Watergate-Plus Fire Retardant Wall Underlay
[BRANZ Appraisal 710](#) - Thermakraft Covertex 403 Absorbent Breathable Roof Underlay
[BRANZ Appraisal 711](#) - Thermakraft Covertex 403 Fire Retardant Absorbent Breathable Wall Underlay
[BRANZ Appraisal 743](#) - Thermakraft Covertex 405 Absorbent Breathable Roof Underlay
[BRANZ Appraisal 803](#) - Bulldog™/Aluminium Window Sealing System
[BRANZ Appraisal 878](#) - Thermakraft Aluband Window Flashing Tape
[Code Mark Certificate 30029](#) - Thermakraft Covertex 403 Absorbent Breathable Roof Underlay
[Code Mark Certificate 30030](#) - Thermakraft Covertex 405 Absorbent Breathable Roof Underlay
[Code Mark Certificate 30028](#) - Thermakraft Covertex 407 Absorbent Breathable Roof Underlay

Manufacturer/supplier contact details

Company: Thermakraft Industries (NZ) Ltd
Web: www.thermakraft.co.nz
Email: info@thermakraft.co.nz
Telephone: 0800 806 595

Warranties

- 1.5 **WARRANTY - MANUFACTURER/SUPPLIER**
Warrant this work under normal environmental and use conditions against failure of materials and execution. Thermakraft Industries Ltd warrant performance of products if design and installation complies with relevant technical literature, NZBC, and recognised industry Codes of Practice. Copy of Thermakraft Product Warranty available on request.

Requirements

- 1.6 **NO SUBSTITUTIONS**
Substitutions are not permitted to any specified materials, or associated products, components or accessories.
- 1.7 **INSTALLATION SKILL LEVELS**
Installers to be experienced in the installation of Thermakraft products and familiar with Thermakraft Industries technical literature and the related documents listed in this design i.e. [NZMRM CoP](#) NZ metal roof and wall cladding Code of Practice.

2. PRODUCTS

Materials

DPC

- 2.1 **EMBOSSSED POLYETHYLENE**
Supercourse 500™ hi-impact polyethylene film to [AS/NZS 2904](#) and embossed on both sides. Thickness 500 microns minimum, manufactured for use as a damp-proof course and concealed flashings around doors and windows and to [BRANZ Appraisal 329](#). Refer to SELECTIONS for type of jointing tape.

Wall underlays

- 2.2 **SYNTHETIC BREATHER TYPE FILM COATED WALL UNDERLAY**
Watergate-Plus™, absorbent breathable spun bonded non-woven polyolefin type building membrane, coated with a water resistant vapour permeable film. A fire retardant membrane, with Flammability Index of ≤ 5 , when tested to AS 1530.2. The product has a [BRANZ Appraisal 695](#).

Roofing underlays

- 2.3 **SYNTHETIC FIRE RETARDANT SELF SUPPORTING NON-WOVEN ROOFING UNDERLAY**
CoverTek™ 407, a fire retardant non-woven self supporting roofing underlay, consisting of two spun-bonded polyolefin fabric layers bonded to a micro porous inner layer, designed for use as a water absorbent, breathable, water resistant roofing underlay for sloped roofs. CoverTek™ 407 has a flammability index of ≤ 5 , tested to AS 1530.2, to [NZBC C/AS1-AS7](#), meets the requirements for suspended fabrics, [BRANZ Appraisal 651](#) and [Code Mark Certificate 30028](#). Can be used in areas exposed to view in occupied spaces.
- 2.4 **SYNTHETIC NON-WOVEN SELF SUPPORTING ROOFING UNDERLAY**
CoverTek™405, a non-woven self-supporting roofing underlay, consisting of two spun-bonded polyolefin fabric layers bonded to a micro porous inner layer, designed for use as a water absorbent, breathable, water resistant roofing underlay for sloped roofs. Covertek™ 405 has a flammability Index of ≤ 5 tested to AS 1530.2, to [NZBC C/AS1-AS7](#), meets the requirements for suspended fabrics, [BRANZ Appraisal 743](#) and [Code Mark Certificate 30030](#). Can be used in areas exposed to view in occupied spaces.

- 2.5 **SYNTHETIC NON-WOVEN HEAVYWEIGHT ROOFING UNDERLAY**
CoverTek™ 403, a non-woven roofing underlay, consisting of two spun-bonded polyolefin fabric layers bonded to a micro porous inner layer, designed for use as a water absorbent, breathable, water resistant roofing underlay for sloped roofs. Covertek™ 403 has a flammability Index of ≤5 tested to AS 1530.2, and meets the requirements of NZBC C/AS2-AS7, 4.17.8. (b) for suspended flexible fabrics.

Accessories

- 2.6 **WINDOW AND DOOR SEALING TAPE**
Thermakraft Aluband™ Window Sealing Tape system consists of synthetic faced reinforced bituminous window sealing tape, Thermakraft Aluband™ Corner Moulding™ piece, used in conjunction with the Thermakraft Aluband™ Hand Tool to ensure good adhesion and a tight fit into corners. See Thermakraft Data Sheet 312 for installation details and BRANZ Appraisal 878.
- 2.7 **WINDOW AND DOOR SEALING TAPE**
Thermakraft Bulldog™ Window Sealing Tape system consists of synthetic faced bituminous window sealing tape, Thermakraft Aluband™ Corner Moulding™ piece, used in conjunction with the Thermakraft Aluband™ Hand Tool to ensure good adhesion and a tight fit into corners. See Thermakraft Data Sheet 312 for installation details and BRANZ Appraisal 803.
- 2.8 **AUSMESH SAFETY MESH**
Ausmesh 300, 2mm x 150 x 300mm galvanized or PVC coated safety mesh to AS/NZS 4389.
- 2.9 **GUTTER AND UNDER FLASHINGS**
Thermakraft 215™, bituminous breather type underlay to NZS 2295 cut to width for use under valley, apron flashing and internal gutters.
Soffit liner cut to width from Thermakraft 215™ bituminous breather type underlay. Refer to SELECTIONS.
- 2.10 **TAPE**
Thermakraft tapes to compliment the underlay. Pressure sensitive aluminium foil tapes for joining foil insulation and vapour barriers. These include:
- Thermakraft White General Purpose Underlay Tape
- Thermakraft Window Sealing Tapes, used to repair damaged bituminous underlays
- 2.11 **DRAINAGE MATT**
Thermakraft Drainage Matt, an extruded 3 dimensional synthetic black mesh, used as an air separation layer between fully sarked roof and roof cladding. Used in wall applications to allow air passage and drainage where no other cavity is provided.

3. EXECUTION

Conditions

- 3.1 **GENERAL REQUIREMENTS**
Design application and installation of Thermakraft Building products to NZBC E2/AS1, BRANZ Appraisals, Thermakraft Technical Literature and Industry Codes of Practice.
- 3.2 **STORAGE**
Store building underlays and accessory materials, under conditions that ensure no deterioration or damage. Store rolls in an upright position on a smooth floor and protected from sunlight, UV radiation and moisture.
- 3.3 **INSPECTION**
Before starting work, check that the building construction phase will allow work of the required standard. Carry out remedial work identified before laying underlay.

Application DPC

- 3.4 **DPC TO LOSP/CCA TREATED TIMBER**
Lay Supercourse 500™ DPC under LOSP or CCA treated bottom plate of all timber framed walls on concrete, in a single layer with 50mm overlaps at joints to provide a waterproof barrier.
- 3.5 **DPC TO TIMBER / STEEL**
Lay DPC under the bottom plate of all timber / steel framed walls on concrete, in a single layer with 50mm overlaps at joints to provide a waterproof barrier. Refer to SELECTIONS for type.
- 3.6 **DPC TO MASONRY AND BRICK VENEER**
Lay DPC along based of cavity and fix top edge to studs with galvanized clouts. Turn DPC out over concrete rebate under bottom course of veneer.

Application - wall underlay

- 3.7 **WALL UNDERLAY**
Fix horizontally to outside face of framing in true alignment, with succeeding sheets overlapping 150mm to NZBC E2/AS1, 9.1.7, Wall underlay, and refer to Thermakraft Industries for requirement for fastenings. Fix to Thermakraft Industries Technical Data specifications. Scribe neatly around penetrations and openings to leave no gaps. Tape all penetrations. Keep clean, undamaged and without visible weather deterioration until closed in.
- 3.8 **METAL CLADDING ON TIMBER CAVITY BATTENS**
Fix strip of Thermakraft DPC as a separator between the timber and metal cladding.

Application - roofing underlay

- 3.9 **SAFETY MESH**
Lay Ausmesh 300 safety mesh over exposed roof areas fixed in accordance with AS/NZS 4389 and NZMRM CoP.
- 3.10 **ROOF UNDERLAY**
Lay vertically over purlins on wire netting with a 150mm side lap. Fix securely to purlins with galvanized fixing clips. Lay underlay to avoid excessive dishing between purlins. When used vertically limit individual runs to 10 metres for bituminous underlays. Do not lay vertically on roof pitches under 10° without support.
- Lay horizontally across the rafter/trusses starting at the gutter line with succeeding sheets in true alignment and lapping 150mm. Scribe around and fit neatly to all penetrations. Avoid prolong exposure by installing the roof immediately.

- 3.11 **GUTTER AND UNDER FLASHINGS**
Lay Thermakraft 215™ bituminous breather type underlay cut to width by manufacturer for use as an underlay to valley, apron flashings, and internal gutters. Lap under flashings with adjoining underlays. Fix Thermakraft 215™ bituminous breather type underlay soffit liner from top plate down 150mm past ribbon plate.

Completion

- 3.12 **CLEAN UP**
Clean up as the work proceeds.
- 3.13 **LEAVE**
Leave work to the standard required by following procedures.
- 3.14 **REMOVE**
Remove debris, unused materials and elements from the site.

4. **SELECTIONS**
For further details on selections go to www.thermakraft.co.nz.

Substitutions are not permitted to the following, unless stated otherwise.

Damp Proof Course

- 4.1 THERMAKRAFT - SUPERCOURSE 500™ DPC
Location: ~
Type: Supercourse 500™ DPC
Jointing tape:

Wall Underlays

- 4.2 THERMAKRAFT WATERGATE-PLUS™
Location: ~
Type: Thermakraft Watergate-Plus™
Jointing tape: ~ *OR 403*

Roofing Underlays

- 4.3 COVERTEK ROOFING UNDERLAYS *403*
Location: ~
Type: ~
Jointing tape: ~

Window / Door Sealing System

- 4.4 THERMAKRAFT - ALUBAND™
Location: ~
Type: Thermakraft window sill tape 75mm Aluband™
- 4.5 THERMAKRAFT BULLDOG™
Location: ~
Type: Thermakraft Bulldog™,

Safety Mesh

- 4.6 THERMAKRAFT - AUSMESH 300
Location: ~
Type: Ausmesh 300
Finish: ~

Gutter and Under Flashing

- 4.7 GUTTER AND UNDER FLASHINGS
Location: ~
Type: ~
Jointing tape: ~

4241S STEEL & TUBE PROFILED METAL WALL CLADDING

1. GENERAL

This section relates to the supply and fixing of **Steel & Tube** profiled metal wall cladding complete with accessories.

1.1 RELATED WORK

Refer to 4161 UNDERLAYS, FOIL AND DPC for underlays, foils and DPC.

1.2 ABBREVIATIONS AND DEFINITIONS

Refer to the general section 1232 INTERPRETATION & DEFINITIONS for abbreviations and definitions used throughout the specification.

The following abbreviations apply specifically to this section:

BMT Base metal thickness
NZMRM New Zealand Metal Roofing Manufacturers Inc.

Documents

1.3 DOCUMENTS

Refer to the general section 1233 REFERENCED DOCUMENTS. The following documents are specifically referred to in this section:

NZBC E2/AS1 External moisture
AS/NZS 1170.2 Structural design actions - Wind actions
AS 1397 Continuous hot-dip metallic coated steel sheet and strip - Coatings of zinc and zinc alloyed with aluminium and magnesium
AS/NZS 2728 Prefinished/pre painted sheet metal products for interior/exterior building applications - Performance requirements
AS 3566 Self-drilling screws for the building and construction industries
NZS 3604 Timber-framed buildings
NZMRM CoP New Zealand Metal Roofing Manufacturers Code of Practice

1.4 MANUFACTURER/SUPPLIER DOCUMENTS

Manufacturer's and supplier's documents related to this section are

- NZ Steel: Specifiers and Builders Guide
- NZ Steel: Installers Guide
- Product Technical Statements
- Design Solutions

Copies of the above literature are available from Steel & Tube

Web: www.steelandtube.co.nz
Email: info@steelandtube.co.nz
Telephone: Freephone 0800 333 247

Warranties

1.5 WARRANTY - MANUFACTURER/SUPPLIER

Provide a material manufacturer/supplier warranty in accordance with published supplier's guidance on materials, environments and building types:

15 years minimum For perforation
15 years minimum For coating

- Provide warranties on Steel & Tube's standard **Warranty Plus** format.
- Commence the warranty from the date of installation.

1.6 WARRANTY - INSTALLER/APPLICATOR

Provide a material manufacturer/supplier warranty:

5 years Workmanship
From: Date of installation

- Provide warranties on Steel & Tube's standard **Warranty Plus** warranty form

- Commence the warranty from the date of installation.

Refer to the general section 1237 WARRANTIES - INSTALLER/APPLICATOR for additional requirements.

Requirements

- 1.7 **NO SUBSTITUTIONS**
Substitutions are not permitted to any specified Steel & Tube products, or associated components and products.
- 1.8 **QUALIFICATIONS**
Installers to be Steel & Tube Approved Installers. A list of recommended installers can be obtained at www.steelandtube.co.nz, or by telephoning Freephone 0800 333 247 or from the local Steel & Tube sales office.

Performance - Wind

- 1.9 **DESIGN PARAMETERS - NON SPECIFIC DESIGN**
Building wind zone ~ / ~ kPa ULS (refer to [NZS3604](#), table 5.4)
Refer to Steel & Tube for "Wind Load Span Design Graphs" for load parameters.
- 1.10 **FIXINGS, WIND**
Design and use the fixings/fixing pattern appropriate for the wind design parameters and NZ Metal Roof and Wall Cladding - Code of Practice. Refer to Steel & Tube Roofing Solutions Product Guide for the selected profile. Allow for specific loadings at corners and the periphery of the cladding, where localised pressure factors apply. Fixing pattern to also take into account fixing method and girt/frame spacing.

Performance - General

- 1.11 **CO-ORDINATE**
Set cladding to vertical plumb lines and maintain verticality. Set all exposed fixings with horizontal string lines. Carefully set out sheets with side laps away from the main line of sight, and with the widths of end sheets the same. Check during fixing to eliminate creep or spread and to keep fastenings in line.
- 1.12 **SPREAD OF FIRE**
To [NZBC C/AS1-AS7,5.8.2 a](#) **Exterior surface finishes.**
- 1.13 **PERFORMANCE**
Install roofing material and associated flashings and accessories to form a weather tight and durable system.

2. PRODUCTS

Materials

- 2.1 **PRE-FINISHED ALUMINIUM/ZINC ALLOY COATED STEEL**
Formability G550 steel sheet coated to [AS/NZS 2728](#).
Coating class: AZ 150
- 2.2 **FASTENERS GENERALLY**
Minimum Category 5 and durability not less than the roofing material being fixed. Screw fasteners to be head stamped identifying the manufacturer and class.
- 2.3 **FIXING CLIPS**
Galvanized steel (thermoplastic powder coated or SS 304 for aluminium) to suit the material and profile of the rigid sheet and location as specified by **Steel & Tube**. Fix to steel with 16mm x 10 gauge galvanized wafer head self-drilling screws and to timber with 30mm x 10 gauge galvanized wafer screws to [NZBC E2/AS1, 8.4.9](#).

2.4 **FIXING SCREWS**
To AS 3566. Screws appropriate to the cladding material and the supporting structure, as required by **Steel & Tube** and with a durability no less than the material fixed. Screws into timber to penetrate by minimum 30mm.

2.5 **RIVETS**
Sealed aluminium, minimum diameter 4mm for use with zinc coated, zinc/aluminium coated or aluminium cladding.

Components

2.6 **FLASHINGS GENERALLY**
Material, grade and colour as detailed and scheduled. Ensure that materials used for flashings are compatible with the window frame materials and fixings and cladding materials and fixings. Where flashings are required but are not detailed, design to **Steel & Tube's** approved design solutions.

2.7 **FLASHINGS**
To **NZBC E2 /AS1, 4.0 Flashings**.
Formable grade 0.55 BMT for galvanized, aluminium/zinc-coated and pre-painted steel, and 0.90 for aluminium (or 0.7mm for small aluminium flashings) to the same standards as the profiled sheets, notched where across profile or provided with a soft edge.

2.8 **WALL AND PARAPET FLASHINGS**
To **NZBC E2/AS1, 4.0 Flashings**.
Supplied by the cladding manufacturer to match or to suit the cladding.

2.9 **CLOSURE STRIPS**
Non-bituminous compressible, profiled foam strips to fit the sheet profile, or pre notched perforated metal closures.
Brand/Type: Ecofoam

Accessories

2.10 **WIRE NETTING**
Refer to 4161 UNDERLAYS, FOIL AND DPC.

2.11 **WALL UNDERLAY**
Refer to 4161 UNDERLAYS, FOIL AND DPC.

2.12 **SEALANT**
Steel & Tube neutral curing silicone or MS polymer sealant and used as directed.

2.13 **LAP SEALING TAPE**
Closed cell self adhesive Trimseallap tape.

3. EXECUTION

Conditions

3.1 **INSPECTION**
Inspect the wall framing and supporting structure to ensure that it is complete and fully braced ready for cladding.

3.2 **STORAGE**
Stack cladding and accessories on clean, level areas of the site and protect from mechanical damage, wind damage and contamination. Loosely cover dry sheeting, with any wet sheeting fillet or cross stack to allow air to circulate. Remove strippable protective film, if applied, prior to prolonged exposure to sunlight.

- 3.3 **FRAMING TIMBER MOISTURE**
For transverse flashings the framing moisture content to be a maximum of 18%..
Transverse flashings can be temporarily tacked in place and final fixing done when moisture content is acceptable.
- 3.4 **HANDLING**
Avoid distortion and contact with damaging substances, including cement. Do not drag sheets across each other and other materials. Protect edges and surface finishes from damage.
- 3.5 **SEPARATION**
Isolate dissimilar materials in close proximity as necessary by painting the surfaces or fitting separator strips of compatible materials. Place isolators between metals and treated timber and cement based materials. Do not use unpainted lead sheet or copper in contact with or allow water run-off onto galvanized and aluminium/zinc-coated metals.
- Application**
- 3.6 **SET-OUT**
Set cladding to vertical plumb lines and maintain verticality. Set all exposed fixings with horizontal string lines. Carefully set out sheets with side laps away from the main line of sight, and with the widths of end sheets the same. Check during fixing to eliminate creep or spread and to keep fastenings in line.
- 3.7 **AVOID END LAPS**
End laps are not permitted, except where specifically detailed.
- 3.8 **FIXING GENERALLY**
Install and fix in accordance with the [NZMRM CoP](#). Use only screws as specified by **Steel & Tube**. Paint colour matched fixings and accessories before installation.
- 3.9 **FIX UNDERLAYS**
Refer to 4161 UNDERLAYS, FOIL AND DPC.
- 3.10 **PENETRATIONS**
Confirm that exterior wall openings have been prepared ready for the installation of all window and door frames and other penetrations through the cladding. Required preparatory work includes the following:
- wall underlay to openings finished and dressed off ready for the installation of window and door frames and other penetrations
- claddings neatly finished off to all sides of openings
- installation of flashings (those required to be installed prior to installation of penetrating elements).
- 3.11 **MARKING AND CUTTING**
Cut only by shearing tools. Do not use black lead pencils for marking Zinalume[®], galvanized, Colorsteel[®] or Colorcote[®] products.
- 3.12 **FIX SHEETS**
Fix sheets in place using the fastening system specified by **Steel & Tube** making due allowance for dynamic local wind pressures on the building and thermal movement in the sheet. Where battens are installed fasten cladding through battens to primary structure. Ensure fixings penetrate 30mm into primary timber structure.
- 3.13 **INSTALL FLASHINGS**
Flash to penetrations, cap corners and edges, using sealant and rivets to detail, to **Steel & Tube's** requirements and to [NZBC E2/AS1](#).
- 3.14 **COMPLETE**
Ensure the work is complete with all flashings, finishing and trim properly installed so the cladding system is completely weathertight.

- 3.15 **SEPARATION**
Separate metal sheeting from CCA treated timber with wall underlay or other suitable isolation material.

Completion

- 3.16 **REPLACE**
Replace all damaged or marked elements.
- 3.17 **LEAVE**
Leave this work complete with all necessary flashings and capping all properly installed as the work proceeds so the finished cladding is completely weathertight.
- 3.18 **REMOVE**
Remove debris, unused materials and elements from the site.

4311S STEEL & TUBE PROFILED METAL ROOFING

1. GENERAL

This section relates to the supply and fixing of **Steel & Tube** profiled metal roofing, complete with accessories.

1.1 RELATED WORK

Refer to 7411S STEEL & TUBE RAINWATER SPOUTING SYSTEMS for rainwater disposal.

1.2 ABBREVIATIONS AND DEFINITIONS

Refer to the general section 1232 INTERPRETATION & DEFINITIONS for abbreviations and definitions used throughout the specification.

The following abbreviations apply specifically to this section:

BMT	Base metal thickness
NZMRM	New Zealand Metal Roofing Manufacturers Inc
MS	Modified silicone

Documents

1.3 DOCUMENTS

Refer to the general section 1233 REFERENCED DOCUMENTS. The following documents are specifically referred to in this section:

NZBC E2/AS1	External moisture
AS/NZS 1170.2	Structural design actions - Wind actions
AS 1397	Continuous hot-dip metallic coated steel sheet and strip - Coatings of zinc and zinc alloyed with aluminium and magnesium
NZS 2295	Pliable, permeable building underlays
AS/NZS 2728	Prefinished/pre painted sheet metal products for interior/exterior building applications - Performance requirements
AS 3566	Self-drilling screws for the building and construction industries
NZS 3604	Timber-framed buildings
AS/NZS 4200.1	Pliable building membranes and underlays - Materials
AS/NZS 4200.2	Pliable building membranes and underlays - Installation requirements
AS/NZS 4534	Zinc and zinc/aluminium-alloy coatings on steel wire
NZMRM CoP	NZ Metal Roof and Wall Cladding Code of Practice

1.4 MANUFACTURER/SUPPLIER DOCUMENTS

Manufacturer's and supplier's documents related to this section are:

Steel & Tube's literature, including:

Product Guide
Product Technical Statements
Design Solutions
NZ Steel: Specifiers and Builders Guide
NZ Steel: Installers Guide

Copies of the above literature are available from Steel & Tube

Web: www.steelandtube.co.nz
Email: info@steelandtube.co.nz
Telephone: Freephone 0800 333 247

Warranties

1.5 WARRANTY - MANUFACTURER/SUPPLIER

Provide a material manufacturer/supplier warranty in accordance with published supplier's guidance on materials, environments and building types:

15 years minimum For Perforation
15 years minimum For coatings

- Provide warranties on Steel & Tube standard **Warranty Plus** format.

- Commence the warranty from the date of installation.

1.6 WARRANTY - INSTALLER/APPLICATOR

Provide an installer/applicator warranty:

Warrant this work under normal environmental and use conditions against weatherproofing failure.

5 years: For workmanship
Form: Roofing installers standard form

- Provide this warranty on the installer/applicator standard form.
- Commence the warranty from the date of installation.

Include a copy of the Steel & Tube maintenance requirements with the warranty.
Refer to the general section 1237 WARRANTIES - INSTALLER/APPLICATOR for additional requirements.

Requirements

1.7 NO SUBSTITUTIONS

Substitutions are not permitted to any specified Steel & Tube products, or associated components and products.

1.8 QUALIFICATIONS

Roofers to be Steel & Tube Approved Installers. A list of approved installers can be obtained from the Steel & Tube website, by telephone or from the local Steel & Tube sales office.

Web: www.steelandtube.co.nz
Email: info@steelandtube.co.nz
Telephone: Freephone 0800 427 663

Performance - Wind

1.9 DESIGN PARAMETERS - NON SPECIFIC DESIGN

Building wind zone ~ / ~ kPa ULS (refer to [NZS3604](#), table 5.4)
Refer to Steel & Tube for "Wind Load Span Design Graphs" for load parameters.

1.10 FIXINGS, WIND

Design and use the fixings/fixing pattern appropriate for the wind design parameters and [NZMRM CoPNZ](#) metal roof and wall cladding Code of Practice. Refer to Steel & Tube Product Technical Statements for the selected profile. Allow for specific loadings at corners and the periphery of the roof, where localised pressure factors apply. Fixing pattern to also take into account fixing method and purlin spacings.

Performance - General

1.11 PERFORMANCE

Install roofing material and associated flashings and accessories to form a weather tight and durable system.

1.12 DRINKING WATER

Roofing for collecting potable water to [NZBCG12/AS1](#).

1.13 CO-ORDINATE

Co-ordinate to ensure substrate and preparatory work is complete and other work programmed in the order required for access and completion of the roof. Ensure that all necessary members are positioned so that flashings can be fastened at both edges through the roof profile or cladding to the primary structure.

2. PRODUCTS

Materials

2.1 PRE-FINISHED ALUMINIUM/ZINC ALLOY COATED STEEL
Formability G550 steel sheet coated to [AS/NZS 2728](#)
Coating class: AZ 150

2.2 TRANSLUCENT ROOFING
Steel & Tube translucent sheeting.

Fixings

2.3 FASTENERS GENERALLY
Minimum Category 5 and durability not less than the roofing material being fixed. Screw fasteners to be head stamped identifying the manufacturer and class.

2.4 FIXING SCREWS
To AS 3566. Screws appropriate to the roofing material and the supporting structure, as required by the roofing manufacturer and with a minimum Category 5 durability and not less than the material being fixed. Screws into timber to penetrate by minimum 30mm.

2.5 RIVETS
Sealed aluminium, minimum diameter 4mm, for use with zinc coated, zinc/aluminium coated or aluminium roofing.

Components

2.6 FLASHINGS GENERALLY
To E2/AS1, 4.0, **Flashings**.
Formable grade 0.55mm BMT for galvanized, aluminium/zinc-coated and pre-painted steel, and 0.90mm for aluminium (or 0.7mm for small aluminium flashings) to the same standards as the profiled sheets, notched where across profile or provided with a soft edge. Where flashings are required but are not detailed, design to Steel & Tube's approved recommendations and designs.

2.7 FLASHINGS TO VERGE, RIDGE AND HIP
To E2/AS1, 4.0, **Flashings**.
Supplied by the roofing manufacturer to match or to suit the roofing.

2.8 BOOT FLASHINGS
Generally to E2/AS1, 8.4.17 **Roof penetrations** (note; E2/AS1, Figure.54 **Soaker flashing for pipe penetration**, has an error, use as guide only).
EPDM proprietary pipe flashing laid on 45° bias to roofing, with over-flashing (soaker flashing) if required.
A boot flashing should be positioned so that it dams a roofing pan no more than 50%, if this cannot be avoided use an over-flashing back to the ridge and fix the boot flashing to that.

Accessories

2.9 WIRE NETTING AND SAFETY MESH
Refer to 4161 UNDERLAYS, FOIL AND DPC.

2.10 UNDERLAY AND REFLECTIVE FOIL
Refer to 4161 UNDERLAYS, FOIL AND DPC.

2.11 SEALANT
Neutral curing silicone or MS polymer sealant as required by Steel & Tube and used as directed.

2.12 CLOSURE STRIPS
Compressible, profiled, closed cell foam strips to fit the sheet profile.

2.13 LAP SEALING TAPE
Closed cell self adhesive Trimseal lap tape.

3. EXECUTION

Conditions

3.1 INSPECTION

Inspect the roof framing and supporting structure to ensure that it is complete and fully braced ready for roofing and free from any misalignments or protrusions that could adversely affect the roofing.

3.2 FRAMING TIMBER MOISTURE

For transverse flashings the framing moisture content to be a maximum of 18%. Transverse flashings can be temporarily tacked in place and final fixing done when moisture content is acceptable.

3.3 STORAGE

Stack roofing and accessories on clean, level areas of the site and protect from mechanical damage, wind damage and contamination. Loosely cover dry sheeting, with any wet sheeting fillet or cross stack to allow air to circulate. Remove strippable protective film, if applied, prior to prolonged exposure to sunlight.

3.4 HANDLING

Avoid distortion and contact with damaging substances, including cement. Do not drag sheets across each other and other materials. Protect edges and surface finishes from damage. Use soft, flat soled shoes when fixing and for all other work on the roof.

3.5 SEPARATION

Place isolators between dissimilar metals and separate roofing from treated timber and cement based materials. Do not use unpainted lead sheet or copper in contact with or allow water run-off onto galvanized or Zinalume[®] materials.

Application

3.6 SET-OUT

Carefully set out with consideration of the position of side laps to take account of the line of sight. Ensure all sheets are square and over-sailing the gutter true to line. Check during fixing to eliminate creep or spread and string lines along purlin centres to keep fastenings in line.

3.7 END LAPS

End laps are not permitted, except where specifically detailed.

3.8 FIXING GENERALLY

Install and fix in accordance with the [NZMRM CoP NZ](#) requirements, and to Steel & Tube's recommendations. Paint colour matched fixings and accessories before installation.

3.9 MARKING AND CUTTING

Cut only by shearing tools. Do not use black lead pencils for marking aluminium/zinc coated products.

3.10 FIX SHEETS

Fix sheets in place using the fastening system required by Steel & Tube for specified profiles, making due allowance for dynamic local wind pressures on the building and thermal movement in the sheet.

3.11 INSTALL TRANSLUCENT SHEETING

Separate translucent sheeting from mesh and netting over purlins with protective GRP strips. Fasten to purlins using recommended fasteners fitted with profiled washers. Fit "U" shaped stop ends to upper edges, secure with rivets and seal with approved sealant.

Where run lengths exceed 12 metres, end laps may be formed and sealed with approved sealant or Trimseal tape at each end of lap.

- 3.12 **STOP ENDS AND DOWNTURNS**
Form stop-ends at the upper end of sheets. Form downturns at the gutter line where the roof pitch is less than 8 degrees. Form using purpose made tools.
- 3.13 **FLASHINGS**
Flash roof to parapets, walls and penetrations to detail. Where no detail is provided flash to NZMRM CoP NZ recommendations and Steel & Tube's requirements. Cut accurately and fix using sealant and rivets to detail and to Steel & Tube's requirements to form a weatherproof cover. For highly visible flashings, plan joints/junction to take account of the aesthetic requirements.
- 3.14 **USE OF SEALANTS**
Select and use sealants only as recommended by Steel & Tube. Apply sealant in two narrow beads transversely across flashing intersections, close to the two edges. Avoid exposing sealant on outside surfaces.
- 3.15 **FLASHING PENETRATIONS**
Flash all penetrations through the roof. Fit pipe flashings with a proprietary collar flashing to manufacturer's requirements, with other penetrations flashed as detailed and to provide a weathertight installation. Ensure that flashings are set to avoid any ponding of water.
- 3.16 **INSTALL RIDGING**
Install ridging by fastening to the purlins through the leading edge of the roofing. Do not fasten transverse flashings to timber with moisture content >18%.

Completion

- 3.17 **REPLACE**
Replace damaged or marked elements. Do not attempt to repair coatings by applying colour match paint to pre-finished surfaces.
- 3.18 **LEAVE**
Leave this work complete with all necessary flashings, undercloaks, valleys, ridges and hips all properly installed as the work proceeds so the finished roof is completely weathertight.
- 3.19 **REMOVE**
Remove trade rubbish and unused materials from the roof and surrounds daily during the work. Sweep down at the end of each day, and clean out spouting, gutters and rainwater pipes on completion of the roof. Remove debris, unused materials and elements from the site.

4520 ALUMINIUM WINDOWS AND DOORS

1. GENERAL

Refer to 1213 SELECTIONS/drawings for specific product, material, accessories and finish selections.

1.1 QUALIFICATIONS

Fabricators/Installers to be experienced, competent trades people familiar with the materials and techniques specified.

1.2 CERTIFICATION

Provide documentation that the windows and doors comply with [NZS 4211](#) and safety glass complies with [NZS 4223.3](#) as modified by [NZBC F2/AS1](#) and [NZBC B1/AS1](#).

1.3 WIND LOADINGS

Refer to section 1212 COMPLIANCE for wind zone.

2. PRODUCTS

2.1 WINDOW AND DOOR REVEALS

As selected, manufactured to comply with [NZS 4211](#). Timber jamb liners to [NZS 3602](#).

2.2 FLASHINGS

To [NZBC E2/AS1](#), 9.1.10 **Windows and Doors** and as required.

2.3 ANODISED ALUMINIUM

To [WANZ SFA 3503-03](#). Thickness 12 microns generally, 20 microns for more corrosive areas and 25 microns for coastal areas and severe corrosive areas.

2.4 SEALANT, GLAZING TAPE AND GASKETS

To the window manufacturer's requirements.

2.5 FIXINGS

Ensure fixings and bracketing are compatible with aluminium. Do not use electroplated zinc fasteners or brass fastenings.

3. EXECUTION

3.1 OPENING PREPARATION

Confirm framing openings (including jamb battens for direct fix cladding) on site for dimension, plumb and straightness prior to fabrication or ordering of aluminium joinery. Prepare and trim to [WANZ Window Installation Guide](#) requirements. For openings over 600mm wide on cavity construction provide sill support bars.

3.2 EXECUTION GENERALLY

To [NZBC E2/VM1](#) and [NZBC E2/AS1](#). Install to [WANZ Window installation Guide](#) requirements.

3.3 HANDLING

Avoid distortion of elements during transit, handling and storage. Prevent pre-finished surfaces from rubbing together. Prevent contact with mud, plaster and cement. Do not deliver to site any elements which cannot be immediately unloaded into suitable conditions of storage.

3.4 CORROSION PROTECTION

Seal or suitably coat cut ends and holes drilled in aluminium before the frames are installed. Before fixing, apply bituminous coatings, slips or underlays between dissimilar metals in contact, or aluminium in contact with concrete.

- 3.5 **FIX FRAMES**
Fix frames rigidly in place without distortion, to the window manufacturer's requirements and to [NZBC E2/AS1](#), 9.1.10.8, **Attachments for windows and doors**, plumb, true to line and face, weathertight and with all openings operating freely.
- 3.6 **DRAINAGE**
Anti-condensation channels to sills. All sills to sashes and fixed lights to incorporate positive drainage to the exterior.
- 3.7 **GLAZING INSTALLATION**
All glass held in aluminium beads and black PVC gaskets.
- 3.8 **SAFETY GLASS INSTALLATION**
Use in doors, sidelight panels, low level windows and all other locations to comply with [NZS 4223.3](#), as modified by [NZBC F2/AS1](#), 1.0 **Glazing** and [NZBC B1/AS1](#), 7.0 **Glazing**.
- 3.9 **INSTALL FLASHINGS**
Install flashings to heads, jambs and sills of frames as supplied and required by the window manufacturer and as detailed on the drawings. Finish on head flashings to match window finish.
- 3.10 **SEAL FRAMES ON SITE**
Seal frames to each other and to adjoining structure and finishes, all as required by the window manufacturer and to make the installation weathertight. Provide a continuous internal air seal between reveals and framing, using sealant over a backing rod.
- 3.11 **SAFETY**
Indicate the presence of transparent glasses for the remainder of the contract period, with whiting, tape or signs compatible with the glass type. Indicators other than whiting must not be applied to the glass surface. Permanent manifestations to comply with [NZS 4223.3](#), 303.1 **Manifestations** (making glass visible).
- 3.12 **CLEAN GLASS AND FRAMES**
Clean off or remove glass indicators at completion of the building. Clean glass inside and out to a shining finish. Clean down both sides of window and door frames using the methods required by the window and door manufacturer.

7410 RAINWATER SPOUTING SYSTEM

1. GENERAL

Refer to 1213 SELECTIONS/drawings for specific product, material, accessories and finish selections.

1.1 LIAISON

Ensure liaison with associated installations to ensure material selections are compatible and required flashing work is completed.

1.2 ELECTROLYTIC ACTION

Avoid electrolytic action by eliminating contact or continuity of water between dissimilar metals.

2. PRODUCTS

2.1 ALUMINIUM/ZINC ALLOY COATED PRE-PAINTED STEEL SPOUTING

Profile, jointing, brackets and fittings brand matched and complete to the spouting manufacturer's specifications.

2.2 ALUMINIUM/ZINC ALLOY COATED PRE-PAINTED STEEL DOWNPIPES

Seam jointed and complete with stand-off brackets, galvanized screw fixed.

2.3 RAINWATER HEADS, DROPPERS, OVERFLOWS

Fabricate and install as detailed.

3. EXECUTION

3.1 INSTALL ALUMINIUM/ZINC ALLOY COATED STEEL PRE-PAINTED SPOUTING AND DOWNPIPES

Screw fix brackets, set to falls to outlets, with spouting joints silicone sealed and pop-riveted to the spouting manufacturer's requirements. Screw fix stand off brackets, set pipes plumb and clear of the wall, with joints silicone sealed. Discharge into stormwater bends.

3.2 ENSURE

Ensure rainwater services are operational, flashings complete and the building weathertight.

CUSTOM ORB

✦ Profiled Metal Roofing and Cladding

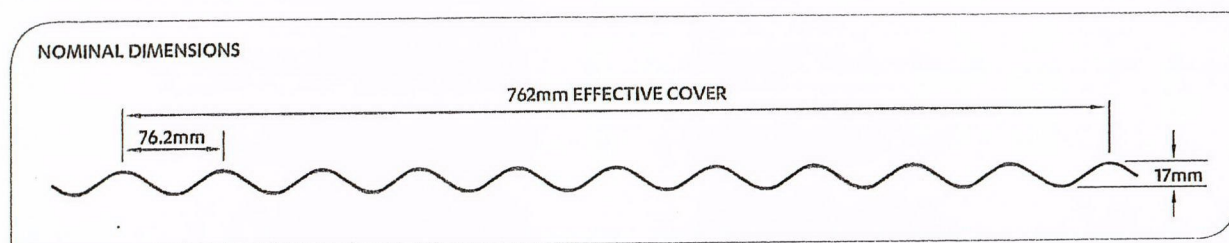

DESCRIPTION

Custom Orb is a premium quality corrugated profile manufactured under licence to BHP.

APPLICATIONS

- Residential Roofing & Cladding
- Industrial/Commercial Roofing & Cladding
- Curving
- Specialty Cladding
- Ceilings and Linings

FEATURES

Corrugated steel is a timeless classic. **Custom Orb** is manufactured to controlled tolerances, allowing it to be used with confidence in a great variety of applications.

Custom Orb can be roll curved (bullnosed) to 400mm radius, or spring curved to radii greater than 9 metres depending on grade, thickness and material used (see *Spring Curved Custom Orb Design Guide* for details). It is also popular in perforated patterns for decorative or sound control situations. Matching translucent sheeting is available in G.R.P. (fibreglass) and Polycarbonate.

MATERIALS

Available in metallic coated and pre-painted steel in .40mm and .55mm B.M.T. (base metal thickness), aluminium plain and pre-painted in .70mm and .90mm, and other non-ferrous metals.

FASTENERS

Typically: Steelfix 12g x 45mm, Timberfix 12g x 55mm, Class 4 minimum, of material compatible with that being fastened and durability no less than the sheet material. Class 5 or non-ferrous fasteners are recommended for severe or very severe marine environments.

DURABILITY

All material selections must be compatible with prevailing environmental conditions and adjacent materials, see *Roofing Solutions Product Guide* or *Specifiers Guide* for details. Areas not exposed to rain washing will require programmed maintenance.

WARRANTY PLUS

Steel & Tube **WarrantyPlus** is the most comprehensive warranty available in the industry. **WarrantyPlus** covers an extended range of performance criteria, is supported back-to-back by our suppliers, includes site-specific maintenance requirements and is transferable to subsequent owners.

FAR NORTH DISTRICT COUNCIL
Approved Documents



PERFORMANCE DATA

MASS (KG/M²)

.40mm B.M.T.	4.08	.55mm B.M.T.	5.54
--------------	------	--------------	------

MAXIMUM SPANS

Base Metal Thickness (mm)	Maximum Spans (mm)	
	Roof	Walls
0.40	1200	1800
0.55	1600	2400

FASTENING REQUIREMENTS

Base Metal Thickness (mm)	Fixings per sheet per support	Roof Span (mm)		
		900	1200	1500
0.40	3	.	.	N/R
	4	.	.	N/R
	5	.	.	N/R
0.55	3
	4
	5

* Suitable for Controlled Traffic ** Suitable for Heavy Traffic N/R Not Recommended

Wind Zone	High	Very High	Extra High	SED
Design Wind Speed (m/s)	<44m/s	<50 m/s	<55 m/s	<60m/s
Load ULS (kPa)	2.32	3.00	3.63	4.32

Notes:

- End spans should be not more than 2/3 of maximum internal spans.
- Sheet ends should be fastened through every second crest.
- To correlate Wind Zone figures to kPa a local pressure factor of 2 has been applied to the entire roof. Specific design is required for roofs designed in accordance with NZS1170 where a local pressure factor of 3 occurs over areas greater than one sheet width or end purlin spacing.
- The above tables are governed by serviceability load factors applicable to normal buildings (importance level 2) for all geographic areas.

MINIMUM PITCH

In accordance with Acceptable Solution E2, the minimum pitch for **Custom Orb** for roofing dwellings is 8°. Roof runs in excess of 12 metres should be checked for water runoff capacity.

FOOT TRAFFIC

Foot traffic up the roof must take place with load spread equally across two crests, or over purlin lines. Traffic across the roof must take place along purlin lines.

SPECIFICATIONS

Recommended specifications are available in the branded sections of MasterSpec **BASIC** or MasterSpec **STANDARD**, or from your local Steel & Tube branch or visit www.steelandtube.co.nz.

DESIGN DETAILS

Design details covering many applications are available on our website in CAD and PDF under each product section. Visit www.steelandtube.co.nz.

Note:

Trademarks apply to the following products presented in this publication: MasterSpec **BASIC** and MasterSpec **STANDARD**.

IMPORTANT PUBLICATIONS

For your installation to perform to its potential, it is essential that it is designed, installed and maintained in accordance with good trade practice. Please refer to:

- Steel & Tube: Roofing Solutions Product Guide
- Steel & Tube Roofing Products: Spring Curved Custom Orb Design Guide
- New Zealand Steel: Installation Guide
- New Zealand Steel: Builders and Specifiers Guide
- BRANZ: Good Profiled Metal Roofing Practice
- MRM: New Zealand Metal Roofing and Wall Cladding Code of Practice
- E2/AS1

INSTALLERS

A list of local installers for your area and contract type is available from your local Steel & Tube branch or visit www.steelandtube.co.nz.

✦ Profiled Metal Roofing and Cladding

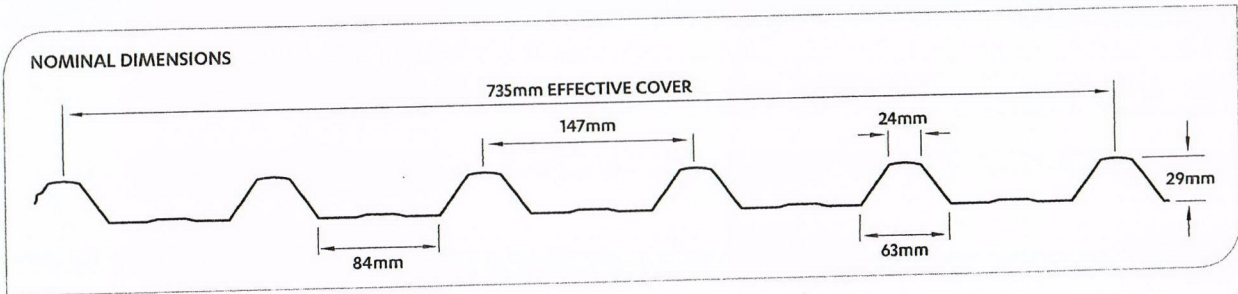

DESCRIPTION

Trimline is a premium low rib, six-ribbed trapezoidal profile, offering great looks and exceptional performance.

APPLICATIONS

- Residential Roofing & Cladding
- Industrial/Commercial Roofing & Cladding
- Curving

FEATURES

Trimline has an extra rib compared to most other products in its class, giving it unequalled good looks and greater rigidity.

OPTIONS

Trimline in .55 G300 material can be crimp curved to minimum radii of 400mm. Depending on grade and purlin spacings, it can be sprung curved down to convex radii of 28 metres. Clear sheeting is available in G.R.P. (fibreglass).

MATERIALS

Available in metallic coated and pre-painted steel in .40mm and .55mm B.M.T. (base metal thickness) aluminium plain and pre-painted in .70mm and .90mm, and other non-ferrous metals.

FASTENERS

Typically: Steelfix 12g x 55mm, Timberfix 12g x 65mm, Class 4 minimum of material compatible with that being fastened and durability no less than the sheet material. Category 5 or non-ferrous fasteners are recommended for severe or very severe marine environments

DURABILITY

All material selections must be compatible with prevailing environmental conditions and adjacent materials, see *Roofing Solutions Product Guide* or *Specifiers Guide* for details. Areas not exposed to rain washing will require programmed maintenance.

WARRANTY PLUS

Steel & Tube **WarrantyPlus** is the most comprehensive warranty available in the industry. **WarrantyPlus** covers an extended range of performance criteria, is supported back-to-back by our suppliers, includes site-specific maintenance requirements and is transferable to subsequent owners.

PERFORMANCE DATA

MASS (KG/M²)

.40mm B.M.T.	4.07	.55mm B.M.T.	5.52
--------------	------	--------------	------

MAXIMUM SPAN

Maximum spans for normal and heavy traffic in millimetres based on Point Load limits, Distributed Loads in kPa calculated in accordance with AS/NZS 1170:2003 at maximum spans, using 4 fasteners per sheet per support. Loads for alternative fastener frequencies available on request.

	Material Thickness	Internal Span			End Span		
		Span	Strength Load	Serviceability Load	Span	Strength Load	Serviceability Load
Controlled Traffic*	.40mm	1700	4.45	3.03	1450	4.95	3.31
	.55mm	2300	5.35	2.12	1700	6.21	3.96
Heavy Traffic**	.40mm	1100	7.07	6.00	800	8.01	5.70
	.55mm	1800	8.19	4.27	1400	7.43	5.65

* Supports 1.1kN to PAN at mid-span. ** Supports 1.1kN to RIB at mid-span.

To minimise the possibility of roof traffic damage, Steel & Tube recommends Heavy Traffic maximum spans be used.

FASTENERS PER SHEET PER PURLIN

Material Thickness	Purlin Spacing	Wind Zone				
		Low 32 m/s	Medium 37 m/s	High 44 m/s	Very High 50 m/s	Extra High 55 m/s
.40mm	900	2	2	3	3	3
.55mm		2	2	2	2	3
.40mm	1200	2	3	3	4	5
.55mm		2	2	2	3	3

Fastener requirements for Wind Zones according to NZS3604:2011 (calculated on periphery area pressures), using standard fasteners without load spreading washers (typically fastened through every rib to top and bottom purlin).

For SED conditions and applications designed to AS/NZS 1170 refer to Steel & Tube: 0800 333 247.

MINIMUM PITCH

In accordance with Acceptable Solution E2, the minimum pitch for **Trimline** for roofing dwellings is 3°. Roof runs in excess of 35 metres should be checked for water runoff capacity.

FOOT TRAFFIC

Foot traffic up the roof must take place in the pan of the profile, or over purlin lines. Traffic across the roof must take place along purlin lines.

SPECIFICATIONS

Recommended specifications are available in the branded sections of MasterSpec **BASIC** or MasterSpec **STANDARD**, or from your local Steel & Tube branch or visit our website.

DESIGN DETAILS

Design details covering many applications are available on our website in CAD and PDF under each product section. Visit www.steelandtube.co.nz.

Note:

Trademarks apply to the following products presented in this publication: **Trimline**, **MasterSpec BASIC** and **MasterSpec STANDARD**.

IMPORTANT PUBLICATIONS

For your installation to perform to its potential, it is essential that it is designed, installed and maintained in accordance with good trade practice. Please refer to:

- Steel & Tube: Roofing Solutions Product Guide
- New Zealand Steel: Installation Guide
- New Zealand Steel: Builders and Specifiers Guide
- BRANZ: Good Profiled Metal Roofing Practice
- MRM: New Zealand Metal Roofing and Wall Cladding Code of Practice
- E2/AS1

INSTALLERS

A list of local installers for your area and contract type is available from your local Steel & Tube branch or visit www.steelandtube.co.nz.



CALL US TODAY

0800 333 247



COVERTEK™₄₀₃

FIRE RETARDANT

ABSORBENT BREATHABLE SYNTHETIC NON-WOVEN ROOF & WALL UNDERLAY

APPLICATION AND INSTALLATION

Product Description **COVERTEK₄₀₃** FIRE RETARDANT ABSORBENT BREATHABLE SYNTHETIC NON-WOVEN ROOF AND WALL UNDERLAY consists of a microporous water resistant film, sandwiched between two layers of mould and shrink resistant spun-bonded polyolefin, and is designed as a condensation control for roofs and walls.

COVERTEK₄₀₃ is a five layer polymer structure that is designed to prevent water penetration without impeding the passage of water vapour.

COVERTEK₄₀₃ is manufactured with an upper layer of tear resistant synthetic spun-bond, and a lower layer of tear resistant synthetic spun-bond facing down. Both layers are designed to protect the inner water resistant microporous membrane.

Flammability **COVERTEK₄₀₃** has a flammability index ≤ 5 and therefore meets the requirements of NZBC Acceptable Solutions C/AS1 Part 6 Table 6.2 for surface finish requirements for suspended flexible fabric, and therefore it may be used without restrictions in all buildings.

Product Advantages **COVERTEK₄₀₃** is a unique layer membrane with these important features:

- can be used in direct fix or cavity fix for roof and wall construction
- is more stable and more shrink resistant than kraft based products
- may be installed during adverse conditions (rain) without affecting its durability and performance
- will not increase risk of condensation as compared with comparable kraft underlays
- has an edge tear greater than 140N
- has a 150mm lap line printed on each edge.

Application **ROOF**

DOMESTIC:- LONG-RUN METAL ROOFING / VERTICAL OR HORIZONTAL INSTALLATION METHOD

COVERTEK₄₀₃ can be direct fix or cavity fix and must be installed in a manner that prevents ponding of water, and span no more than 300mm without additional support.

For purlin spacings greater than 300mm

COVERTEK₄₀₃ must be supported by **Thermakraft Safety Mesh** 300mm x 150m, or hexagonal netting 50mm or 75mm.

For roof pitches below 10 degrees, refer to

COVERTEK₄₀₇ FIRE RETARDANT SELF SUPPORTING ABSORBENT BREATHABLE SYNTHETIC NON-WOVEN ROOF UNDERLAY.

COVERTEK₄₀₃ must be laid firmly (tight) without creases. All laps either vertical or horizontal must have a minimum of 150mm lap. To achieve a lap seal (refer to NZ Metal Roofing Code of Practice 4.3.8 and 4.3.9).

Use **Thermakraft Window Sealing Tape ALUBAND.**

COVERTEK₄₀₃ Fix using stainless steel 8-12mm staples or 20mm flat head clouts, or appropriate proprietary fastenings.

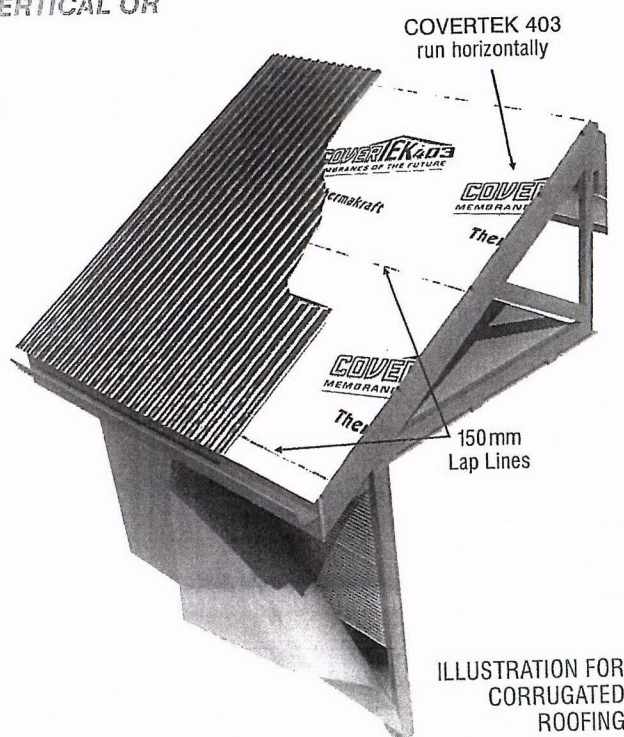

ILLUSTRATION FOR
CORRUGATED
ROOFING

APPLICATION AND INSTALLATION . . . contd

COMMERCIAL:- LONG-RUN METAL ROOFING >10°

COVERTEK 403 shall be installed in a manner that prevents ponding of water by full support using **Thermakraft Safety Mesh** 300mm x 150m, or hexagonal netting 50mm or 75mm.

COVERTEK 403 may be installed either vertically (same direction as the roof) or horizontally using the shi-lap method. All laps either horizontally or vertically must be at a minimum of 150mm.

COVERTEK 403 to be lapped into gutter 20mm and extended up to and over ridge.

COVERTEK 403 may be unwound to the full length from the gutter to the ridge. However, when ridge ventilation is required **COVERTEK 403** must be terminated at the ridge purlin to allow a free passage of air.

Flue penetrations must have a minimum distance of 50mm from the **COVERTEK 403** (refer to NZ Metal Roof and Wall Cladding Code of Practice 4.3.8).

COVERTEK 403 must be free of tears and punctures, fit tightly and be lap taped around all penetrations (except flue penetrations), to provide drainage for any condensation, or surface water from leaks. **NOTE: Do not use ALUBAND on penetrations where Polybutene water pipes have been installed. Refer Pipe Manufacturers for instructions on sealing penetrations.**

COVERTEK 403 can be installed above the battens or purlins for profiled metal roof claddings and otherwise in accordance with NZBC E2/AS1.

LONG-RUN METAL ROOFING Wooden Construction

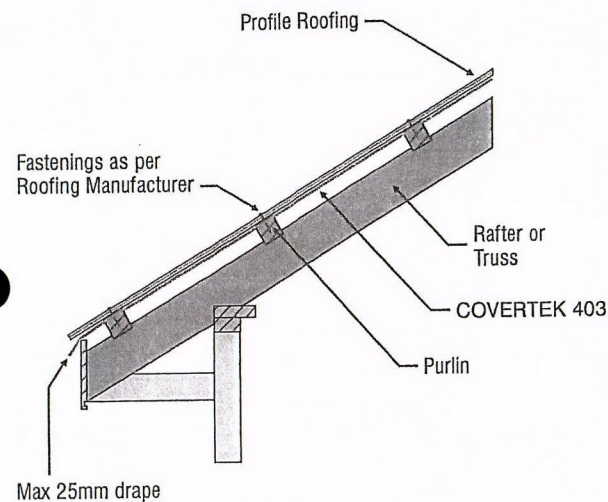

LONG-RUN METAL ROOFING Steel Construction

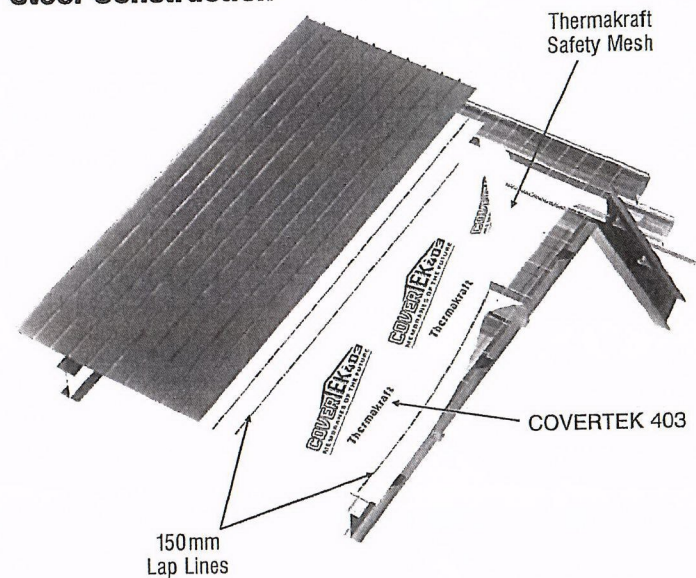

For more information regarding **Thermakraft ALUBAND Window Sealing System** (BRANZ No.614 (2008) refer to the "APPLICATION and INSTALLATION GUIDELINES" or contact **Thermakraft Customer Services** on **0800 806 595**.

APPLICATION AND INSTALLATION . . . contd

Application WALL

COVERIEK403 can be used as a wall underlay on timber framed buildings with absorbent and non-absorbent wall claddings directly fixed to the framing.

COVERIEK403 can be used as a wall underlay on steel framed buildings with absorbent and non-absorbent wall claddings.

COVERIEK403 is suitable for use in all Building Wind Zones of NZS 3604 up to, and including "Very High".

COVERIEK403 will provide temporary weather protection during construction. Translucency of the underlay will enable work to proceed during inclement weather.

COVERIEK403 can be used as a non-rigid backing material for Stucco Plaster in accordance with the requirements of NZBC Acceptable Solution E2/AS1 Paragraph 9.3.5.1. The underlay must be supported with 75mm galvanized mesh, or **Thermakraft Stud Strap**, or wire at 150mm centres run across cavity battens to limit deflection to a maximum of 5mm in accordance with the requirements of NZBC Acceptable Solution E2/AS1 Paragraph 9.3.5.2.

COVERIEK403 may also be used as a slip layer over rigid backing for Stucco Plaster in accordance with the requirements of NZBC E2/AS1 Paragraph 9.3.3 (b).

COVERIEK403 is unaffected by LOSP treated timbers.

COVERIEK403 must be fixed with printed side out and the non-printed side to the frame.

1. **COVERIEK403** is applied to all exterior walls from below bearers to the top plate. Fix securely to the frame with fasteners such as galvanized 'Little Grippers', 6mm-8mm staples or 20mm large head galvanized clouts at 300mm centres, horizontally and vertically. Additional fasteners should be used around each opening to be cut.

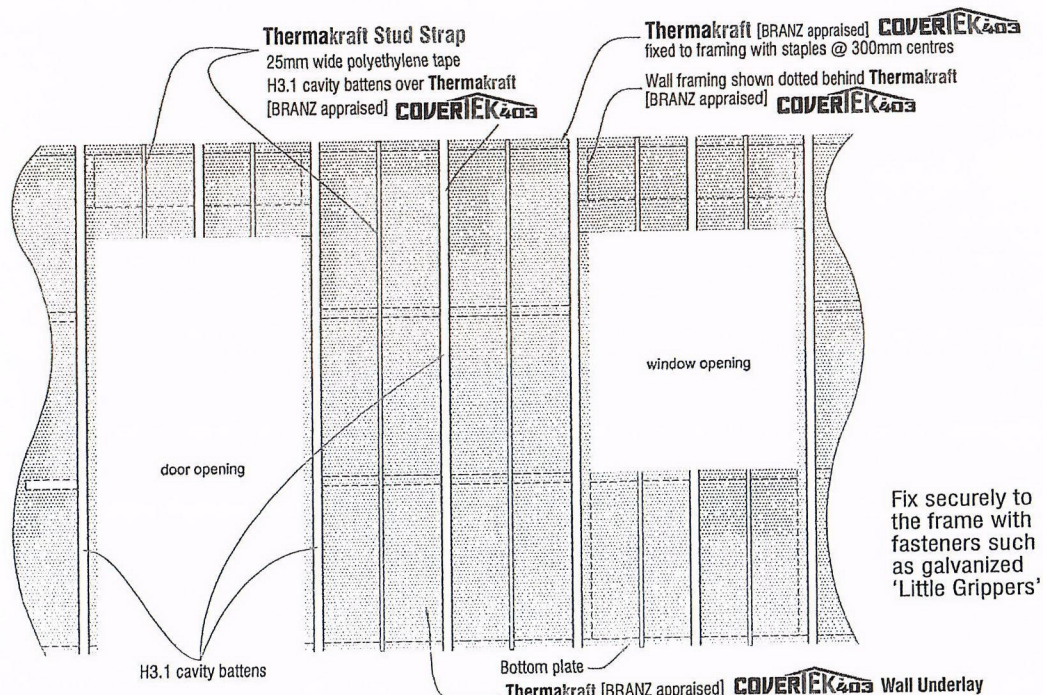

NOTE: Fastenings behind Brick Veneer Cladding must have an equivalent service life to that of Brick Veneer (50 years). Refer to NZBC E2/AS1 Table 20. **NOTE:** All vertical laps must be made over studs. Make good any forced tears with tape.

IMPORTANT NOTE: Drained Cavity System; in accordance with NZBC Acceptable Solution E2/AS1 Paragraph 9.1.8.5, where stud spacings are greater than 450mm centres, an intermediate means of restraining the building underlay and insulation from bulging into the drained cavity shall be installed. An acceptable means of achieving this is **Thermakraft Stud Strap** fixed horizontally at

APPLICATION AND INSTALLATION . . . contd

Application

WALL . . . contd

2. Whether installing **COVERIEK403** horizontally or vertically, a minimum of 150mm lap is required at joints, and all vertical laps must be made over studs.

Make good repairs on any forced tears with **Thermakraft ALUBAND Window Sealing Tape**.

3. **COVERIEK403** Initially cover all windows and door openings. Use extra fastenings around each window or door opening to be cut out. It is recommended that the wall underlay is not cut and prepared for window installation until the arrival of the windows.



Fix securely to the frame with fasteners such as galvanized 'Little Grippers'.



On arrival of doors and windows, cut the **COVERIEK403** at each opening on a 45° angle away from each corner. Pull the **COVERIEK403** flaps inside and fasten to inside of frame.



Application of **Thermakraft Stud Strap** for cavity construction where studs spaced >450mm.



4. **Thermakraft ALUBAND Window Sealing System** is applied prior to fitting windows.

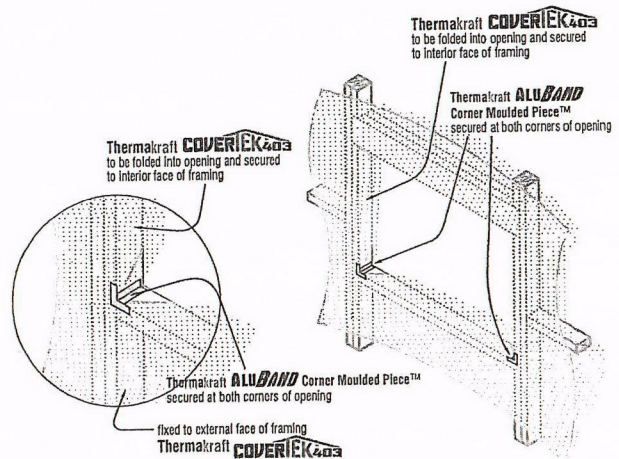
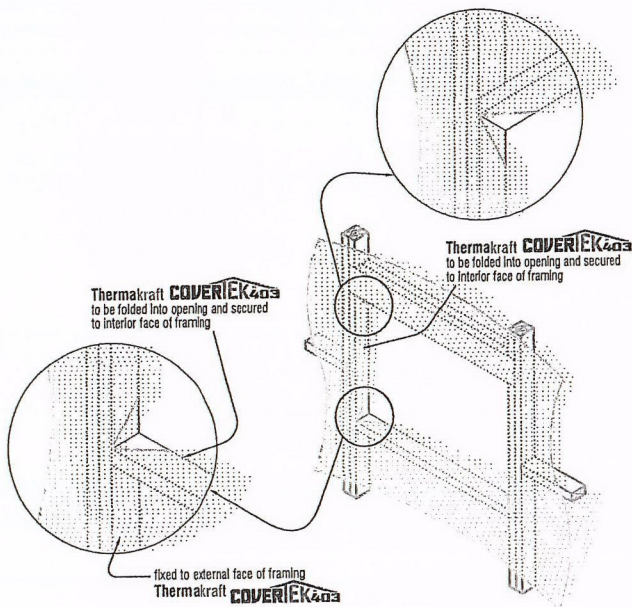

Storage

COVERIEK403 should be stored on end in dry conditions. Protect from the weather and direct sunlight.

Roll Dimensions

COVERIEK403

1350mm x 55.6m = 75m²
 1350mm x 37.0m = 50m²
 1350mm x 18.6m = 25m²

TECHNICAL SPECIFICATIONS

WALL

Product Specifications **COVERIEK403** FIRE RETARDANT ABSORBENT BREATHABLE SYNTHETIC NON-WOVEN ROOF AND WALL UNDERLAY can be used as a wall underlay on timber framed buildings within the following scope:

- the scope limitations of NZBC Acceptable Solution E2/AS1, Paragraph 1.1
- with absorbent and non-absorbent wall claddings directly fixed to the framing; and,
- with absorbent and non-absorbent wall claddings installed over an 18mm minimum drained cavity; and,
- with masonry veneer in accordance with NZS 3604; and,
- situated in NZS 3604 Building Wind Zones up to, and including "Very High".

COVERIEK403 can be used as a wall underlay on steel framed buildings within the following scope:

- the scope limitations of NZBC Acceptable Solution E2/AS1, Paragraph 1.1
- with absorbent and non-absorbent wall claddings
- with masonry veneer in accordance with NZS 3604
- situated in NZS 3604 Building Wind Zones up to, and including "Very High".

COVERIEK403 meets the Performance Requirements of NZBC Clauses B2 Durability B2.3.1 (a) 50 years, B2.3.1 (b) 15 years and B2.3.2, C/AS1 Part 6 Table 6.2 Flammability ≤ 5 , E2 External Moisture, and F2 Hazardous Building Materials F2.3.1.

Durability Requirements **COVERIEK403** meets the Performance Requirements of NZBC Clauses B2 Durability B2.3.1 (a) 50 years, B2.3.1 (b) 15 years and B2.3.2, C/AS1 Part 6 Table 6.2 Flammability ≤ 5 , E2 External Moisture, and F2 Hazardous Building Materials F2.3.1., providing:

- it is not damaged
 - installed in accordance to the **Thermakraft** "Application and Installation Guidelines"
 - it is not left exposed for more than **7** days
 - installed by or under guidance of Licensed Building Practitioners
 - is compatible with cladding system used.
-

TECHNICAL SPECIFICATIONS

ROOF

COVERIEK403 FIRE RETARDANT ABSORBENT BREATHABLE SYNTHETIC NON-WOVEN ROOF AND WALL UNDERLAY can be used as a roof underlay on buildings within the following scope:

- the scope limitations of NZBC Acceptable Solution E2/AS1, Paragraph 1.1; with regards to building height and floor plan area; and,
- with masonry tile roof cladding; and,
- with metal tile and profiled roof cladding; and,
- situated in NZS 3604 Building Wind Zones up to, and including "Very High".

Product Specifications **COVERIEK403** installation must always be carried out in accordance with:

- Thermakraft "Application and Installation Guidelines"
- Installed by or under the direct supervision of a licensed Building Practitioner or qualified Roofer
- NZBC Acceptable Solution E2/AS1 Paragraph 8.0 - 8.4
- NZ Metal Roofing Manufacturers Roof and Wall Cladding Code of Practice
- Metal Roof / Tile Manufacturers specifications

COVERIEK403 must not be left exposed to direct sunlight or UV light sources during its serviceable life;

COVERIEK403 must not be left exposed to the elements on the roof for more than **7** days before being covered;

COVERIEK403 The design application and installation of **COVERIEK403** must follow sound condensation management principles, making use of ventilation and vapour control layers where necessary.

Durability Requirements **COVERIEK403** will meet the Performance Requirements of NZBC:

- Clauses B2 Durability B2.3.1 (a) not less than 50 years, B2.3.1 (b) 15 years and B2.3.2
- Clause C Part 6 Table 6.2: Flammability Index ≤ 5
- Clause E2 External Moisture: Performance E2.3.2 when used as part of the Roof Cladding System
- Clause F2 Hazardous Building Materials: Performance F2.3.1 will not present a health hazard to people.

TABLE 1: NZBC E2/AS1 ALTERNATIVE SOLUTION TO TABLE 23 AS A ROOFING UNDERLAY REQUIREMENT

NZBC E2/AS1 TABLE 23 ROOF UNDERLAY PROPERTIES	PROPERTY PERFORMANCE REQUIREMENT	ACTUAL PROPERTY PERFORMANCE
Absorbency	$\geq 150 \text{ g/m}^2$	$\geq 150 \text{ g/m}^2$
Vapour Resistance	$< 7 \text{ MN.s/g}$	Pass
pH of Extract	$> 6 \text{ and } < 9$	Pass
Shrinkage	$< 0.5\%$	Pass
Water Resistance	$\geq 100\text{mm}$	Pass

ABSORBENT BREATHABLE SYNTHETIC NON-WOVEN ROOF & WALL UNDERLAY

TECHNICAL SPECIFICATIONS

Control Of Condensation

In climatic regions where condensation risks are high, such as cold or high humidity areas, care needs to be taken in specifying the correct design and installation to prevent moisture build-up in the roof cavities.

Factors which adversely affect the condensation risk in roofing systems include;

- Humid, and/or cold climatic regions
- Warm/Skillion roof construction
- Low roof cavity air volume and restricted air movement
- Omitting Vapour Control Layers
- Ceiling penetrations and entry of warm air into roof cavities
- Occupancy activities which have high moisture loading on conditioned spaces
- Low pitched roof
- Bulk insulation
- Building structures ability to naturally dry Construction Moisture

Skillion and Warm Roof Construction are particularly sensitive to moisture accumulation and the design and installation of roof construction needs to take into account the higher condensation risks. Refer MRM Code of Practice for details.

The recommendations contained in **Thermakraft's** literature are based on good building practice, but are not an exhaustive statement of all relevant information and are subject to any conditions contained in the Warranty. All product dimensions and performance claims are subject to any variation caused by normal manufacturing process and tolerances. Furthermore, as the successful performance of the relevant system depends on numerous factors outside the control of **Thermakraft** (for example quality of workmanship and design), **Thermakraft** shall not be liable for the recommendations in that literature and the performance of **the Product**, including its suitability for any purpose or ability to satisfy the relevant provisions of the Building Code, regulations and standards.



CERTIFICATE OF CONFORMITY

This product Certificate is issued under Section 269 of the Building Act 2004 for:

Thermakraft Covertex 403

JAS-ANZ



global-mark

Product Description

Thermakraft Covertex 403 Fire Retardant Roof Underlay is a synthetic building underlay for use under roof claddings. The product consists of a micro-porous water resistant film laminated to two layers of non woven spun-bonded polyolefin. Thermakraft Covertex 403 Fire Retardant Roof Underlay is coloured white on the top and bottom faces.

Product Scope and Technical Specification

Thermakraft Covertex 403 Fire Retardant Roof Underlay has been assessed for use as a roof underlay on buildings within the following scope:

- the scope limitations of NZBC Acceptable Solution E2/AS1, (Amendment 5, August 2011 and Errata 2 December 2011) Paragraph 1.1 with regards to building height and floor plan area; and,
- with masonry tile roof cladding; and,
- with metal tile and profiled metal roof cladding; and,
- situated in NZS 3604-2011 Wind Zones up to, and including Extra High.

Thermakraft Covertex 403 Fire Retardant Roof Underlay is supplied in rolls 1.350 m wide x 18.6 m, 37.0 m and 55.6 m long. The product is printed with the Thermakraft Covertex 403 logo repeated along the length of the roll. The rolls are wrapped in clear polythene film.

Accessories used with Thermakraft Covertex 403 Fire Retardant Roof Underlay which are supplied by the installer are:

- Fixings - stainless steel staples, clouts, screws or proprietary underlay fixings, or other temporary fixings to attach the roof underlay to the framing.
- Roof underlay support - polypropylene strap, or minimum 0.9 mm diameter galvanised steel wire mesh where required to support the roof underlay in accordance with NZBC Acceptable Solution E2/AS1 (Amendment 5, August 2011 and Errata 2 December 2011), Paragraph 8.1.5.1. (Note: The mesh must be galvanised in accordance with AS/NZS 4534-2006.)

Product purpose and use

For use as an alternative to conventional kraft paper roof underlay: fixed over timber or steel framed roofs and to assist in the moisture management of roof cladding systems.

Certificate holder

Thermakraft Industries (NZ) Ltd www.thermakraft.co.nz
 11 Turin Place, East Tamaki Auckland, New Zealand
 Tel: +64 9 2733727

CodeMark Certification Body		11/07/2013		GM-CM30029-RevA
Global-Mark Pty Ltd; Suite 4.07, 32 Delhi Road, North Ryde NSW 2113, Australia www.Global-Mark.com.au	Herve Michoux Managing Director	Date of issue	Last update	Certificate Number

The purpose of construction site audits is to confirm the practicability of installing the product; and to confirm the appropriateness and accuracy of installation instructions.
 This certificate is issued by Global-Mark Pty Limited, an independent certification body accredited by the product certification accreditation body (JAS-ANZ) appointed by the Chief Executive of the Department of Building and Housing under the Building Act 2004. The Department of Building and Housing does not in any way warrant, guarantee, or represent that the building method or product the subject of this certificate conforms with the New Zealand Building Code, nor accept any liability arising out of the use of the building method or product. The Department of Building and Housing disclaims, to the extent permitted by law, all liability (including negligence) for claims of losses, expenses, damages, and costs arising as a result of the



CERTIFICATE OF CONFORMITY

This product Certificate is issued under Section 269 of the Building Act 2004 for:

Thermakraft Covertex 403



global-mark

Page 2 of 4

Compliance with the New Zealand Building Code (NZBC):

- **Clause B2 DURABILITY:** Performance B2.3.1(a), not less than 50 years, B2.3.1(b), 15 years and B2.3.2. Thermakraft Covertex 403 Fire Retardant Roof Underlay meets these requirements.
- **Clause E2 EXTERNAL MOISTURE:** Performance E2.3.2. When used as part of the roof cladding system, Thermakraft Covertex 403 Fire Retardant Roof Underlay will contribute to meeting this requirement.
- **Clause F2 HAZARDOUS BUILDING MATERIALS:** Performance F2.3.1. Thermakraft Covertex 403 Fire Retardant Roof Underlay meets this requirement and will not present a health hazard to people.

Subject to the following conditions and limitations:

1. Maintaining the validity of BRANZ Appraisal No. 710 (2010) Thermakraft Covertex 403 Fire Retardant Absorbent Breathable Roof Underlay (refer to www.branz.co.nz).

Design and Installation Conditions:

1. Timber and Steel Framing

Timber and steel roof framing must be provided in accordance with the requirements of the NZBC and the roof cladding manufacturer.

2. General

Table 1: NZBC E2/AS1 (Amendment 5, August 2011 and Errata 2 December 2011) Table 23 Requirements

Roof Underlay Properties	Property Performance Requirement	Results
Absorbency	$\geq 150 \text{ g/m}^2$	Pass $> 150 \text{ g/m}^2$
Vapour Resistance	$\leq 7 \text{ MN s/g}$	Pass
Water Resistance	$\geq 100 \text{ mm}$	Pass
pH of Extract	≥ 6 and ≤ 9	Pass
Shrinkage	$\leq 0.5\%$	Pass
Mechanical	Edge tear and tensile strength	Edge tear (Average): <ul style="list-style-type: none"> • Machine direction = 163 N • Cross direction = 129 N Tensile strength (Average): <ul style="list-style-type: none"> • Machine direction = 3.18 kN/m • Cross direction = 2.56 kN/m

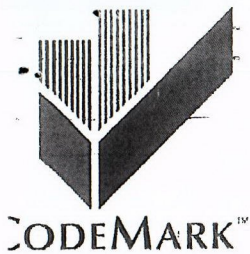

CERTIFICATE OF CONFORMITY

This product Certificate is issued under Section 269 of the Building Act 2004 for:

Thermakraft Covertex 403



Page 3 of 4

Thermakraft Covertex 403 Fire Retardant Roof Underlay is intended for use as an alternative to conventional kraft paper roof underlays, which are fixed over timber or steel framed roofs in order to limit the entry of wind into the roof cavity, and to assist in the moisture management of the roof cladding system.

The material also provides a degree of temporary weather protection during early construction. However, the product will not make the roof weathertight and some wetting of the underlying structure is always possible before the roof cladding is installed. Hence, the entire building must be closed-in and made weatherproof before moisture sensitive materials such as ceiling linings and insulation materials are installed.

Thermakraft Covertex 403 Fire Retardant Roof Underlay must not be exposed to the weather or ultra violet light for a total of more than 7 days before being covered by the roof cladding.

Thermakraft Covertex 403 Fire Retardant Roof Underlay is suitable for use under roof claddings on buildings as a roof underlay as called up in NZBC Acceptable Solution E2/AS1, (Amendment 5, August 2011 and Errata 2 December 2011) Table 23. Refer to Table 1 for the material properties of Thermakraft Covertex 403 Fire Retardant Roof Underlay.

Thermakraft Covertex 403 Fire Retardant Roof Underlay is suitable for use at roof pitches 8° and above. At pitches 8° and above, Thermakraft Covertex 403 Fire Retardant Roof Underlay if supported by a corrosion resistant material can be installed vertically or horizontally and must span no greater than 300 mm in one direction. (Note: For roof pitches less than 8°, Thermakraft recommends the use of Covertex 407 Roof Underlay.)

3. Structure

Thermakraft Covertex 403 Fire Retardant Roof Underlay is suitable for use in all Wind Zones of NZS 3604-2011 up to, and including, Extra High.

4. Durability

Thermakraft Covertex 403 Fire Retardant Roof Underlay meets code compliance with NZBC Clause B2.3.1 (a), not less than 50 years for roof underlays used where the roof cladding durability requirement or expected serviceable life is not less than 50 years, e.g. behind masonry roof tile cladding, and code compliance with NZBC Clause B2.3.1 (b), 15 years for roof underlays used where the roof cladding durability requirement is 15 years.

5. Serviceable Life

Provided it is not exposed to the weather or ultra-violet light for a total of more than 7 days, and provided the roof cladding is maintained in accordance with the cladding manufacturer's instructions and the roof cladding remains weather resistant, Thermakraft Covertex 403 Fire Retardant Roof Underlay is expected to have a serviceable life equal to that of the roof cladding.



CERTIFICATE OF CONFORMITY

This product Certificate is issued under Section 269 of the Building Act 2004 for:

Thermakraft Covertex 403

JAS-ANZ



global-mark

Page 4 of 4

6. Control of Internal Fire and Smoke Spread

Thermakraft Covertex 403 Fire Retardant Roof Underlay has an AS 1530 Part 2 – 1993 (including Amendment 1) flammability index of not greater than 5 and therefore meets the requirements of NZBC Acceptable Solutions C/AS2 to C/AS6, Paragraph 4.17.8 b), for the surface finish requirements of suspended flexible fabric used as an underlay to exterior cladding that is exposed to view in occupied spaces. It may therefore be used with no restrictions in all buildings.

7. Prevention of Fire Occurring

Separation or protection must be provided to Thermakraft Covertex 403 Fire Retardant Roof Underlay from heat sources such as fire places, heating appliances, flues and chimneys. Part 7 of NZBC Acceptable Solutions C/AS1 – C/AS6 (April 2012 and Errata 1) and NZBC Verification Method C/VM1 (April 2012 and Errata 1) provide methods for separation and protection of combustible materials from heat sources.

8. External Moisture

Thermakraft Covertex 403 Fire Retardant Roof Underlay must only be used under roof claddings that meet the requirements of the NZBC, such as those covered by NZBC Acceptable Solution E2/AS1 (Amendment 5, August 2011 and Errata 2 December 2011). Thermakraft Covertex 403 Fire Retardant Roof Underlay, when installed in accordance with the Application and Installation document May 2012, will assist in the total cladding system's compliance with NZBC Clause E2 (Amendment 5, August 2011 and Errata 2 December 2011).

9. Underlay Installation

Thermakraft Covertex 403 Fire Retardant Roof Underlay must be fixed at maximum 300 mm centres to all framing members with large-head clouts 20 mm long, 6-8 mm stainless steel staples, self drilling screws or proprietary underlay fixings. The membrane must be pulled taut over the framing before fixing.

Thermakraft Covertex 403 Fire Retardant Roof Underlay may be run vertically or horizontally at roof pitches greater than 8°. It must extend from the ridge and overhang the fascia board by 20-25 mm. Vertical laps must be no less than 150 mm wide. Horizontal laps must also be no less than 150 mm, with the direction of the lap ensuring that water is shed to the outer face of the underlay. End laps must be made over framing and be no less than 150 mm wide. To assist with achieving the correct lap dimension, Thermakraft Covertex 403 Fire Retardant Roof Underlay has a 150 mm lap line printed continuously along the top face. When fixing the product in windy conditions, care must be taken due to the large sail area created.

Any damaged areas of Thermakraft Covertex 403 Fire Retardant Roof Underlay, such as tears, holes or gaps around service penetrations, must be repaired. Damaged areas can be repaired by covering with new material lapping the damaged area by at least 150 mm and taping, or by taping small tears.

10. Installation Conditions:

Shall be carried out by:

- A Licensed Building Practitioner with experience in roof cladding installation; or,
- By competent tradespersons with an understanding of roof underlay installation.

The installer shall also:

Comply with all relevant technical information relating to the products use, including information contained within the Thermakraft Covertex 403 Fire Retardant Self-Supporting Roof Underlay Application and Installation document May 2012 and the BRANZ Appraisal (refer to www.branz.co.nz).

End of record



MiTek New Zealand Ltd.

CHRISTCHURCH
Phone: (03) 348 8691
Fax: (03) 348 0314

AUCKLAND
Phone: (09) 274 7109
Fax: (09) 274 7100

www.mitek.nz.co.nz

Emails to: farm.buildings@mitek.nz.co.nz

MITEK®

LUMBERLOK®

BOWMAC®

Producer Statement - PS1 - Design

ISSUED BY: MiTek New Zealand Ltd.
TO BE SUPPLIED TO: Building Consent Authorities in New Zealand
IN RESPECT OF: Proposed Lean-To Farm Building - FB35214A
AT: 7849 SH12 Waimamaku.

MiTek New Zealand Ltd has been engaged to provide engineering design services in respect of the requirements of Clause(s) B1 of the Building Regulations 1992.

Part only as specified: Purlins, Rafters, Girts, Poles, Columns, Trusses if applicable (including fixings as specified) and building stability (including foundations) of the proposed building work.

The design has been prepared in accordance with AS/NZS 1170, NZS 3603, NZS 3604, approved documents of the NZ Building Code and the work is described on MiTek New Zealand Ltd drawings numbered FB35214A and the specification and other documents according to which the building is proposed to be constructed.

As an independent design professional covered by a current policy of Professional Indemnity Insurance to a minimum value of \$500,000, I BELIEVE ON REASONABLE GROUNDS that subject to:

1. The verification of the following design assumptions:
 - i) Importance Level 1, Design working Life 50 years
 - ii) Light roof and no ceiling
 - iii) Modified Very High Wind Zone
 - iv) Snow Load $s_g = 0$
 - v) The structure is supporting on good ground- NZS 3604 Section 3, with a soil ultimate bearing capacity 300 kPa, $\phi_b = 0.5$.
2. All proprietary products meeting the performance specification requirements, the drawings, specifications, and other documents according to which the building is proposed to be constructed comply with the relevant provisions of the building code, including B2 - Durability.

I believe on reasonable grounds that the drawings, specifications and other document according to which the building is proposed to be constructed comply with the relevant building code.

On behalf of MiTek New Zealand Ltd

Date: 9 / 12 / 15

.....
In Ling Ng
Technical Services Manager
BE (Hons), CPEng, IntPE
MIPENZ (ID: 146585)



MiTek New Zealand Ltd.

CHRISTCHURCH
Phone: (03) 348 8691
Fax: (03) 348 0314

AUCKLAND
Phone: (09) 274 7109
Fax: (09) 274 7100

www.mitek.nz.co.nz
MITEK®

Emails to: farm.buildings@mitek.nz.co.nz

LUMBERLOK®

BOWMAC®

DESIGN INFORMATION - FARM BUILDING FB35214A

LOADS and TIMBER

- Poles : Poles, Outer Zone Density Normal 350 kg/m³ f_b= 38 MPa, Pole taper 6mm per 1.0m length
- Purlins : Radiata Pine or Douglas Fir - SG8
- Girts : Radiata Pine or Douglas Fir - SG8
- Rafters : Radiata Pine or Douglas Fir - SG8
- Moisture content can be green. Our recommendation is 20% or less at time of installation.

DESIGN LOADS

- Dead loads for Light Roof - 0.25kPa (includes weight of purlins, associated framing and galvanized iron roof).
- Live loads - 1.1kN concentrated load, 0.25kPa uniform Load.
- The enclosed documentation has been designed for a Building Importance level 1, with 50 years working life. Refer to AS/NZS 1170.0:2002.
- Wind loads - building designed for a modified Very High Wind Zone.
- Snow Loads - building designed for sg= 0(calculated specifically for the job site in this documentation)
- Seismic Zone - 1 (Annual Probability of Exceedance - 1/100)
- Soil conditions - ALL foundations to be into natural ground with a minimum bearing capacity of 300 kPa, Øb=0.5.

DESIGN LOAD REFERENCES

Compliance Document for the New Zealand Building Code Clause B1 Structure Amendment 8	
NZS3603:1993 Amendment 4	Cited Verification Method
NZS3604 Amendment 2	Cited Acceptable Solution
AS/NZS 1170 Part 0: 2002	Cited Verification Method
AS/NZS 1170 Part 1: 2002	Cited Verification Method
AS/NZS 1170 Part 2: 2011	Cited Verification Method
AS/NZS 1170 Part 3: 2003	Cited Verification Method
ANSI/TPI1 - 2002	Alternative Solution
Rutledge Method	Alternative Solution - Footing Design for Cantilever Poles.

BUILDING ERECTION

Proper bracing must be installed to hold the components true and plumb and in a safe condition until permanent bracing is fixed. All permanent bracing and fixings must be installed before applying any loads.

LOAD DETAILS

These drawings have been prepared using the above design loads. It is the responsibility of the user to ensure that the design data and loads are still correct at the time of construction.

PRODUCT SPECIFICATION

These details have been designed using specific MITEK®, LUMBERLOK® and BOWMAC® products and the performance of the building and validity of the Producer Statement is reliant on the correct choice of product.

COPYRIGHT

These drawings are the property of MiTek New Zealand Limited and must not be copied or reproduced without permission.

ANC.